

# Research Journal of Pharmaceutical, Biological and Chemical Sciences

## Development Of The Construction And Characterization Of Deep Complex For Collecting IMC.

Dmitrii Yungmeister\*, and Kirill Kireev.

National Mineral Resources University (Mining University), 2, 21st Line, 199106, St Petersburg, Russia.

### ABSTRACT

Due to the depletion of strategic resources, it is necessary to find alternative sources that will make up their supply. The sources, which are able to make up for a stock is iron-manganese concretions located in the Clarion-Clipperton Zone. Iron-manganese concretions are the most common and promising solid minerals for mining. Development of Mineral Resources of the Ocean almost is in its infancy and is mainly produced offshore development and mining activities are carried out at relatively shallow depths. For effective development of offshore fields, especially at great depths, need reliable means of mechanization hydro ascent rock mass with sufficient performance. Currently known devices for the extraction of solid minerals from offshore fields is not effective enough and do not correspond to modern requirements on security, performance, energy consumption and environmental. Known means for carrying out subsea production (mainly) two functions: separation of solid minerals and its transportation to the support vessel (sometimes there may be an additional feature - a partial enrichment). These functions are performed by mechanisms that are divided into mechanical and hydraulic. The most effective technology for subsea production is the separation of these functions, and separation from the array is carried out mechanically, lifting to the surface - hydraulic (hydro lift). For offshore mining need to make a deep-water high-tech equipment. The development of this industry can be made on the basis of existing engineering enterprises producing mining equipment, or with the involvement of military and shipyards.

**Keywords:** Nodules, deepwater mining, manganese, iron-manganese concretions, Pacific Ocean, bottom.

*\*Corresponding author*

## INTRODUCTION

The solution of the problems associated with the development of mineral resources of the oceans, is receiving increasing attention from companies and consortiums and also entire nations. They are working on the improving of the old and the creation of new technical equipment and technologies, aimed at increasing the efficiency of mining of the seabed, while reducing the harmful effects on the environment. Iron-manganese concretions (IMC), widespread at the bottom of the oceans, most concentrated in several ore fields within which they are distributed unevenly, although in some areas nodules cover over 50% of the bottom area. One of the most important characteristics of IMC as the ore is that they occur at the sediment surface or sometimes covered with a thin layer of sediment. This feature defines how the production in a collection of disparate freely lying on the bottom surface. This field development method requires that the concretions occur in sufficient quantities for the efficient operation of the mining device.

Experience of subsea mineral extraction from the bottom of seas and oceans shows, in particular, the following advantages of this method over conventional methods of mining [1]:

- No required special construction of access roads;
- in many cases, the enrichment layer is on the bottom surface and does not require stripping works and preparation works are carried out in small volumes;
- sharply decreases the amount of work on laying waste rock and water enrichment devices;

Development of underwater mineral deposits can be done in a shorter time and at a significantly lower specific investment than in the construction of open cast mines on land.

At present we know a significant number of patents, proposals, plans, projects, experimental and pilot plants for the production of structural nodules from the ocean floor. Modern technology allows underwater exploration and production on an industrial scale only at depths of 50-60 m. Most of the nominated projects to date equipment and production technology ferromanganese nodules are still in the stage of experimental tests. [1-6,7,8]. Currently most nominated devices projects and technologies of production of IMC are still in the stage of pilot testing.

### Known Machines

It is known [9, 10]: classification mechanisms for underwater mining on the type of energy used for the separation of rock mass from the face

Mechanical-hydraulic: multibucket shells and dredge, grab shells and dredge, dragline excavators, scrapers dredge scraper, cable systems, rod missiles, self-propelled and towed scrapers, underwater self-propelled machines (self-propelled vehicles on wheels, self-propelled vehicles on tracks and screw the course, self-installation step).

Mechanical: suction dredger, ejecting shells and dredge with mechanical rippers.

Hydraulic: ejecting shells and dredge with hydraulic rippers, hydraulic dredge, airlift shells [11].

The operating principle of deep mining machinery (DMM) is similar to the intermediate drive. The speed of movement is transferred from the supply vessel (fig. 1) to the DMMs carrying cable. The cable feeds the motor that runs a pump for pumping water from the cavities of the drum and shell. The drum rolled on IMC, lying on the bottom. Due to dilution in the reservoir area of the fixed a capture and keeping nodules on the surface of shell to achieve the upper end of the reservoir sector, where the dilution zone ends and fall into the hopper under the force of gravity nodules. The slope and conical shape of the hopper allows IMC accumulate in the narrow part and buckets conveying belt, bringing them on the supply vessel.

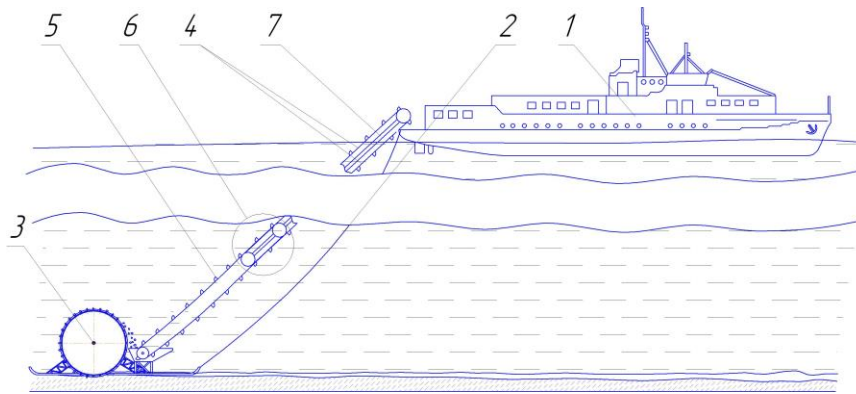

**Figure 1: Complex for production of ferromanganese nodules**

1 - supply vessel; 2 - carrying cable; 3 - deep mining machinery; 4 - transfer belt; 5 - bucket; 6 - intermediate drive; 7 - Pipe becoming

To increase the traction of the mining complex during transportation of minerals extracted from the bottom of the unit to support vessel is used the intermediate drive with vacuum cavities (fig. 2) installed between the full and empty branches of the transport system [9].

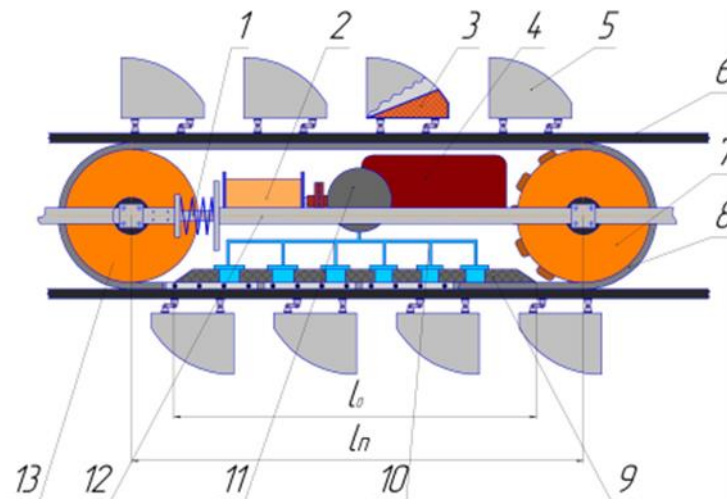

**Figure 2: Intermediate drive**

1 - tensioning mechanism; 2 - electric motor; 3 - the cavity with polystyrene; 4 - gear; 5 - bucket; 6 - transfer belt; 7 - drive pulley; 8 - the drive belt; 9 - a support base; 10 - system of pipes; 11 - pump; 12 - becoming; 13 - driven drum

Intermediate drive implements traction, which can generally be calculated by the formula [10]:

$$F_T = f \left[ l_n \cdot g \cdot \sum_{i=1}^3 m_i \cdot \cos \beta + \Delta p_0 [S + k_H (A - S)] \right], \quad (1)$$

where  $f$  - coefficient of friction between the belts;  $S$  - total area of grooves on the traction belt,  $m_2$ ;  $l_n$  - the length of executive body,  $m$ ;  $A$  - The zone of low pressure,  $m_2$ ;  $k_H$  - ratio unevenness that characterizes how unevenly distributed vacuum created by the pump under the purview of the support base 9 between 8 and traction conveying belts 6 (Fig. 2), with a maximum value of 1 - the system works perfectly, at a value of 0 - system is not working; - The angle of installation of the elevator; - The value of the vacuum, Pa; ;  $m_1$  - mass per unit length tape,  $m_2$  - mass per unit length of buckets,  $m_1 + m_2 = 0$ , since Feed buckets has zero buoyancy;  $m_3$  - linear mass of the load in kg / m; where  $B$  - width of the actuator, m;  $l_0$  - the length of which creates a vacuum, m. long drive IP of 3 m., traction (Formula 1) is 210 kN [8].

This complex (Figure 1) has the following disadvantages. Capture quality nodules depends on the purity of the drum surface. When drum working on the surface with the mud inclusions it's possible to lead to "caulk" holes.

Despite these shortcomings, the complex designed by Yungmeyster DA, Smirnov DV, after modernization and elimination of these drawbacks can be used to collect nodules. Transport from the submersible vessel to the ship will take the same complex (fig.1). However, as the bottom unit (BU) is considered a new design based on the feet and shovel scraper conveyor equipped with crawler and bunker.

**TECHNICAL TASK**

**Development of the prototype deep-mining complex (DMC) for FMN and KMK of the Ocean**

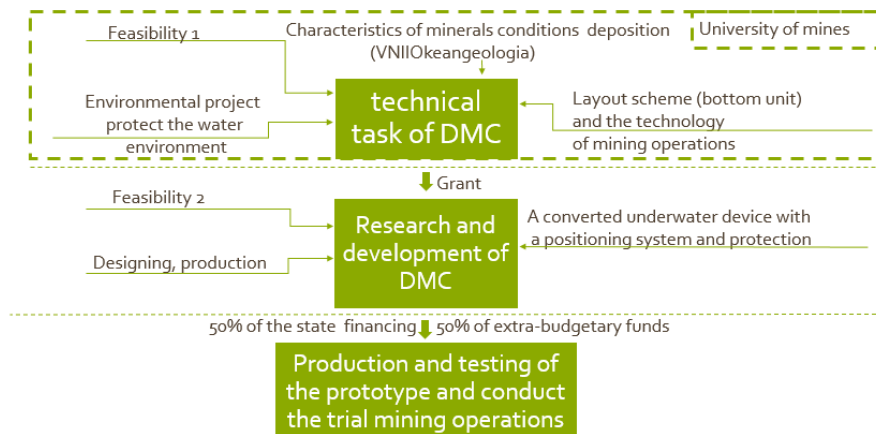

**Figure 3 prospective scheme of technical task.**

The complex consists of a support vessel, the elevator, the intermediate bunker and four underwater mining units. The vessel has an overhead crane and tanks for ore

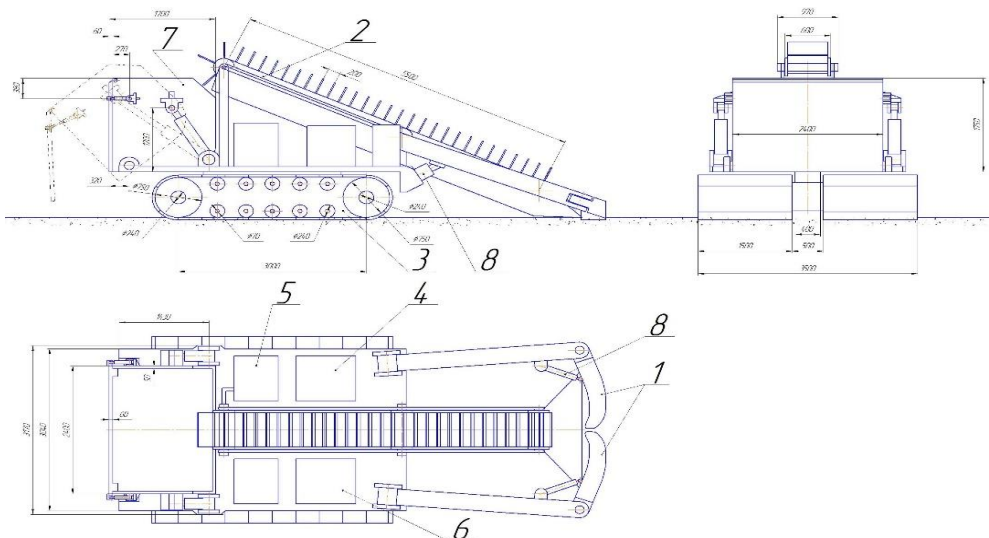

**Figure 3: Bottom unit**

Complex operates as follows. Supply vessel comes to the next square gathering place of IMC and stands on anchor. The intermediate hopper is lowered from the support vessel into the center of the planned square. The hopper is designed as a metal box. The end drum elevator located in the bunker. Axis of drum is

rebound, it is connected with the excitement of the sea and, due to the compression of the springs, and there is no gap between the hopper and the bottom during adverse conditions. After installation, the hopper and the elevator, bottom units (BU) is lowering down. Each BU fulfills field area of  $625 \text{ m}^2$ . The unit has a bunker volume of 4 tons. Once the BU fills his tank, he moved on to the intermediate unloading hopper. Four mining unit carried out a continuous occupancy of the intermediate hopper.

The bottom unit (Fig. 4) has the following basic components: shovel foot (1), the scraper conveyor to the lower working branch (2), crawler truck (3), a motor (4), a hydraulic motor of the scraper conveyor (5), oil station (6), hopper (7), hydraulic cylinders (8). Power unit is carried out by an electric cable.

Asking distributed mass of iron-manganese concretions (IMC), given to the area of their occurrence, as well as the speed of the rowing of his paw, it is possible to determine the amount of collected by IMC in one stroke and theoretical productivity of rowing paws (Figure 4):

$$Q_{II} = \frac{m_p \cdot l_{II}^2}{\rho \cdot t_{II}}, \quad (2)$$

where  $l_{II}$  – the length of the paw,  $l_{II} = 1,5 \text{ m}$ ;  $\rho$  – abundance of IMC,  $\rho = 0,9 \text{ t/m}^3$ ;  $t_{II}$  – cycle time,

$$t_{II} = \frac{l_{II}}{v_{ГР}}, \quad (3)$$

where  $v_{ГР}$  – the speed of the paw  $v_{ГР} = 0,1 \dots 1,0 \text{ m/s}$ . The cycle time  $t_{II}$ , for the speed of the paw of 0.5 m/s it's 3 s.

In Figure 4, plotted from  $Q_{II}$  to  $h_{II}$ . To reduce the hydrodynamic resistance to movement of paws it is expedient to take the minimum possible speed and height of the paws, but they should be achieved the specified performance. Therefore, from the graph on said figure it can be determined the height of the paw, which to  $Q_{II} = 0,025 \text{ m}^3/\text{s}$  and  $l_{II} = 1,5 \text{ m}$  is  $h_{II} = 0,18 \text{ m}$ .

$$h_{II} = \sqrt{\frac{2 \cdot Q_{II}}{l_{II}}} = \sqrt{\frac{2 \cdot 0,025}{1,5}} = 0,18 \text{ m} \quad (4)$$

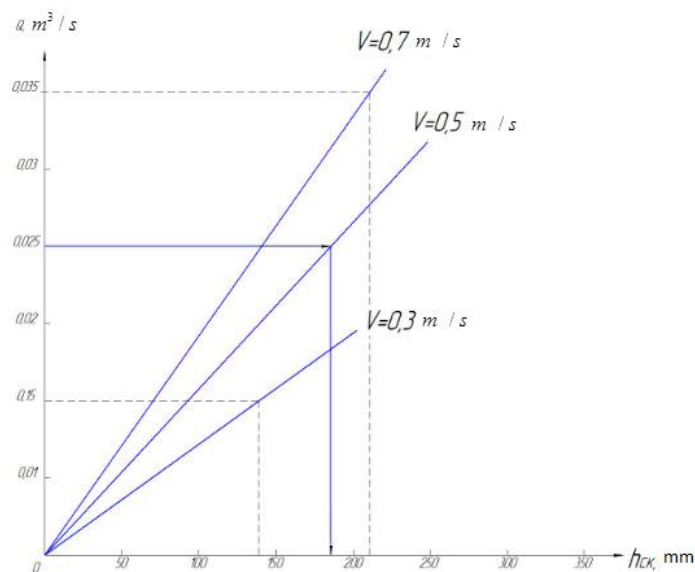

Figure 4: A graph of the performance of the BU height of legs.

The above layout scheme of the bottom unit (BU) and the method of determining the rational parameters of nodes BU allows you to draw up the original design of deep-sea mining machines, aggregates or complexes, to create a prototype.

### CONCLUSIONS

Globally, 1.2 million km<sup>2</sup> of seabed have already been licensed for exploration, creating the largest mining operation the planet has ever seen and dwarfing anything comparable on land. By 2020, it has been estimated that 5% of the world's minerals, including cobalt, copper and zinc could come from the ocean floors. The main obstacle is the lack of production technology that could produce work on an industrial scale on the deep depth. Therefore, it is necessary to develop a machine that would be able to operate at a depth of over 2 km.

### REFERENCES

- [1] Smirnov DV Selection and justification of rational parameters of the executive unit for the production of ferromanganese nodules. Diss. on PhD degree. tehn. Science, SPMI, St. Petersburg, 2009 – 151p.
- [2] Bath, A.R., 1991. Deep sea mining technology: Recent developments and future projects. Mining Engineering : 25-31.
- [3] Bedenbender, J.W., 1970. Electroacoustis characteristics of marine seismiestreamezs. Geophysics : 49-58.
- [4] Bernard J., Bath A., Greger B., "Analysis and Comparison of Nodule Hydraulic Transport Systems" // Offshore Technology Conference Paper, No. OTC 5476, Houston, TX, P. 32-35.
- [5] Brocket F.H., Kollwentz W.M., 1997 "An International Project – Nodule Collectors" // Offshore Technology Conference Paper, No. OTC 2777, Houston, TX, P. 44-46.
- [6] Marine technology reporter // 8th Annual Geo-Spatial Science Conference and College Fair University of New Hampshire, Durham, NH 2006, November, - P. 28-29
- [7] Bubis Y. Current state and prospects of development of ocean deposits of metal-bearing rocks // Mining Journal. - 1994, №3 - C. 186-189.
- [8] Bubis Y. Grishin AA, Semeniuk D. The prospect of the mining complex of the ocean // Mining Gazette. - 1999, №1 - C.88-92.
- [9] Yungmeyster DA, Smirnov DV Drive the vehicle body of the unit for production of ferromanganese nodules // Notes Mining Institute, 2005 T 167 (2) - P. 99-101.
- [10] Yungmeyster DA Bolshunov AV, Smirnov DV Calculation of the parameters of the executive body of the unit for the extraction of seabed nodules // Mountain information-analytical bulletin, 2006, №5, - pp 89-94
- [11] Lezgintsev GM, EA Kontarev The development of deep-sea mineral resources of the oceans .// The results of science and technology. - M: 1976 t.XIV. S.171-174.