

Research Journal of Pharmaceutical, Biological and Chemical Sciences

Justification Of Technological Approaches To The Use Of Sosnovsky Hogweed As Part Of A Feed Additive.

Pavel Nikolayevich Shkolnikov*, Sergei Mikhailovich Dotsenko, Lyudmila Gennadievna Kryuchkova, Victor Vatslavovich Samuylo, and Sergei Anatolyevich Ivanov.

Far East State Agricultural University, Polytechnic str., 86, Blagoveshchensk 675005, Russia.

ABSTRACT

On the basis of the adopted provisions, the necessity and expediency of utilization of Sosnovsky hogweed through its use as part of a protein-carbohydrate additive for farm animals is substantiated. The list of technological operations necessary and sufficient for the development of a constructive-technological scheme of a line for the production of granules and briquettes containing a system of machines to ensure the production of a protein-carbohydrate additive has been substantiated. The parameters of the proposed technical properties are justified.

Keywords: hogweed Sosnowsky, technology, scheme, technical means, operations, parameters.

**Corresponding author*

INTRODUCTION

It is known that the hogweed of Sosnowsky (HS), as a feed crop, has a relatively high value [1]. Previously, this feed crop, due to the relatively high sugar content, was used in the production of silage.

However, at present the plant has turned into a weed, which in a certain sense represents an environmental threat. In this regard, local authorities are making certain, but virtually unsuccessful efforts to destroy it.

At the same time, one of the ways to successfully combat this “weed” can be its use in the production of pellets and briquettes in combination with high-protein feed components. The use of this culture in combination, for example, with non-fatted soy flour gives the necessary sugar-protein ratio in the range (0.8 - 1.5): 1

At the same time, HS feed advantages can be enhanced by harvesting it in the budding phase with subsequent heat treatment during drying of the obtained soy-herbal granules and briquettes.

The purpose of the study is the substantiation of technological approaches to the disposal of HS in feed products with simultaneous selection of a system of machines for their implementation.

Research tasks:

1. To substantiate the technological scheme of the production process for the use of HS in feed products in the form of granules and briquettes;
2. Develop and propose a constructive-technological scheme of the line with a specific system of machines and parameters for the preparation of protein-carbohydrate feed additives for animals.

MATERIAL AND METHODS

The main technological approaches for the disposal of HS in feed products are determined by the combination and sequence of operations, the relationship of which is shown in Figure 1.

At the same time, HS harvesting can be implemented by existing forage harvesters in the budding phase with subsequent delivery and storage of chopped green mass (GM) at the places of its processing.

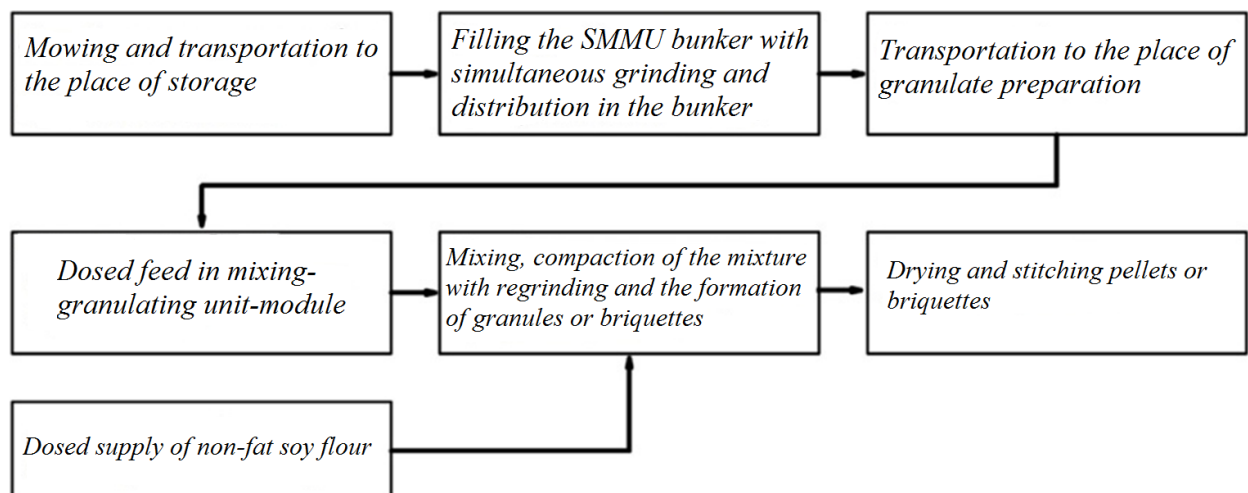

Figure 1: Technological scheme of the preparation of fodder granules and briquettes using Sosnowsky hogweed

At the place of storage and accumulation of GM is loading the mobile feeder with regrinding GM. GM regrinding is performed using a shredding and distributing device (SDD), which is part of a small-sized mobile multifunctional unit (SMMU) (Figure 2) [2, 3].

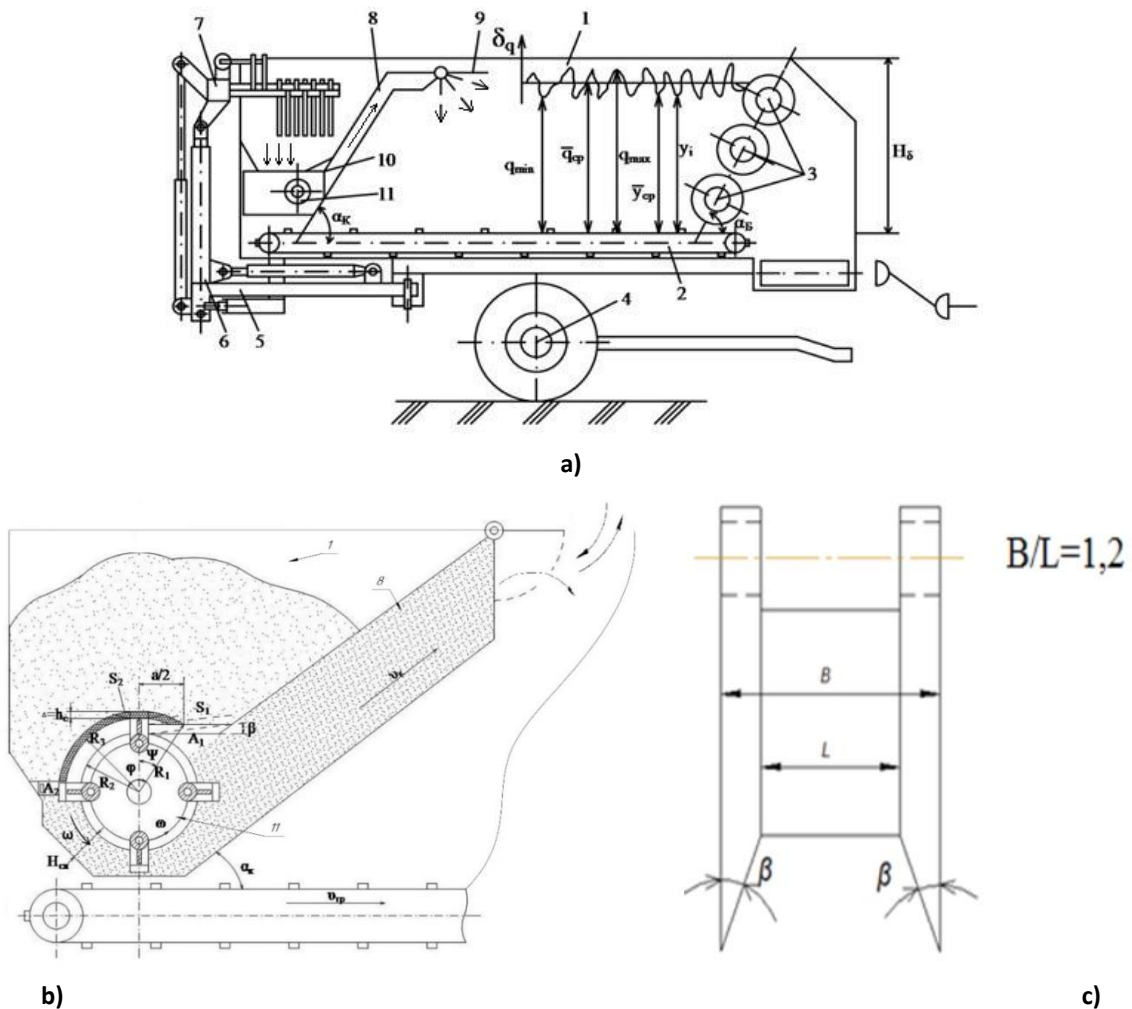

Figure 2: General view of SMMU (a) and its SDD design diagram (b, c)

1 - bunker; 2 - feeding conveyor; 3 - beater; 4 - running gear; 5 - frame; 6 - the manipulator; 7 - capture; 8 - feed line; 9 - distributing visor; 10 - shredder; 11 - the rotor.

In order to obtain expressions for calculating the performance and power expended on the operation of a hammer-type grinding apparatus with hingedly suspended H-shaped hammers, simultaneously playing the role of blades for the distribution of feed particles in the bunker, a study was made of the movement of the feed particle located on the surface of the hinge hammer (Figure 2 b, c).

RESULTS AND DISCUSSION

As a result of a theoretical analysis of the SDD workflow, a dependence has been obtained that characterizes its throughput.

$$Q_u = 9,6(Z_{pi} - \Delta Z_{pi})R_z \cdot \omega \cdot \rho_n \cdot S_i, \quad (1)$$

where Z_{pi} – the length of the rotor due to the width of the hammer-blade; ΔZ_{pi} – lattice plate thickness; R_z – number of hammers going one track; ω – rotor angular speed; ρ_n – food density; S_i – cross-sectional area of the feed portion.

The granulator-briquetting machine was adopted as the baseline, which includes three nodes: a moisture averager mixer (MAM) - 1; pressing-regrinding device (PRD) - 2 and a forming device (FD) - 3. (Figure 3)

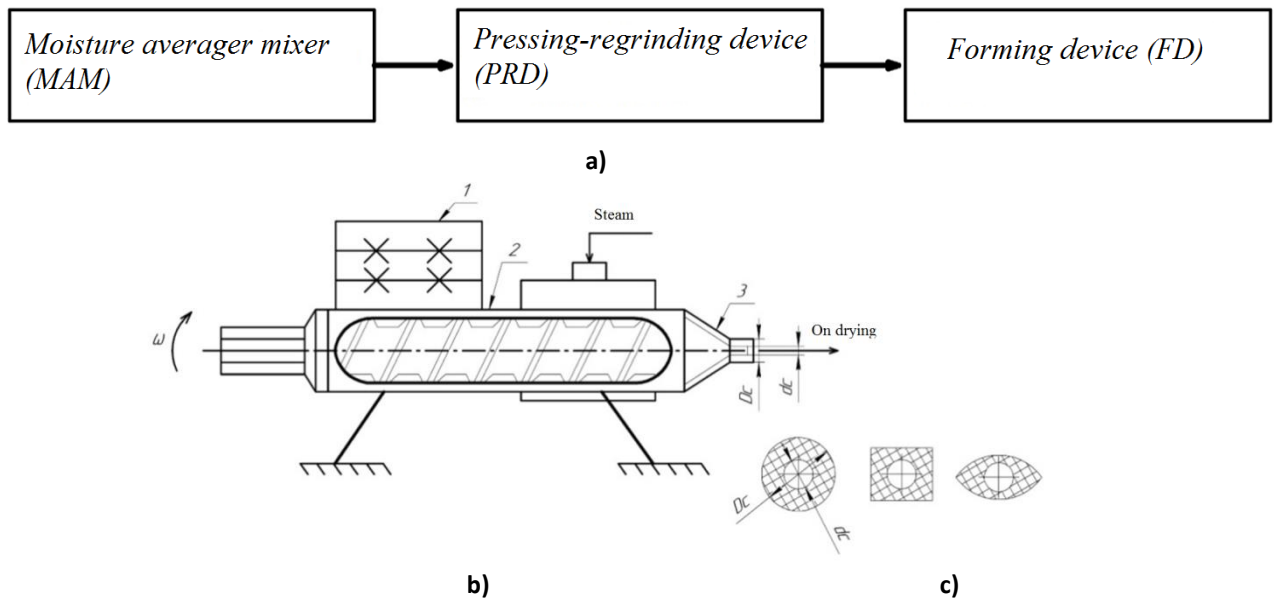

Figure 3: Structural and functional (a) and structural and technological (b) schemes of the granulator-briquetting machine; (c) - transverse configuration of granules and briquettes. 1 - MAM; 2 - PRD; 3 - FD.

Supply of granulator-briquetting machine (GB) is determined by the dependence

$$Q_{GB} = 0,785 \cdot (D_c^2 - d_c^2) \cdot \rho_k \cdot v_{in} \cdot \frac{P_{in}}{P_{fin}}, \quad (2)$$

where D_c and d_c – diameters of the forming and channel nozzles respectively; ρ_k – density of soybean and vegetable composition in the forming unit GB; v_{in} – initial velocity of the composition at the entrance to the forming unit; P_{in}, P_{fin} – pressure, respectively, at the beginning and end of the forming unit.

With a known value of the capacity of the dryer "ESPIS - 4 - Universal" equal Q_d and the mass of the molded product (granules or briquettes) G when their humidity is equal W_{in} drying time will be

$$t_d = Q_d / G [100 - W_{in}/100] \quad (3)$$

Figure 4 shows the constructive-technological scheme of the line with the corresponding system of interrelated technical parameters that ensure the feasibility and feasibility of utilization of HS in feed granules or briquettes.

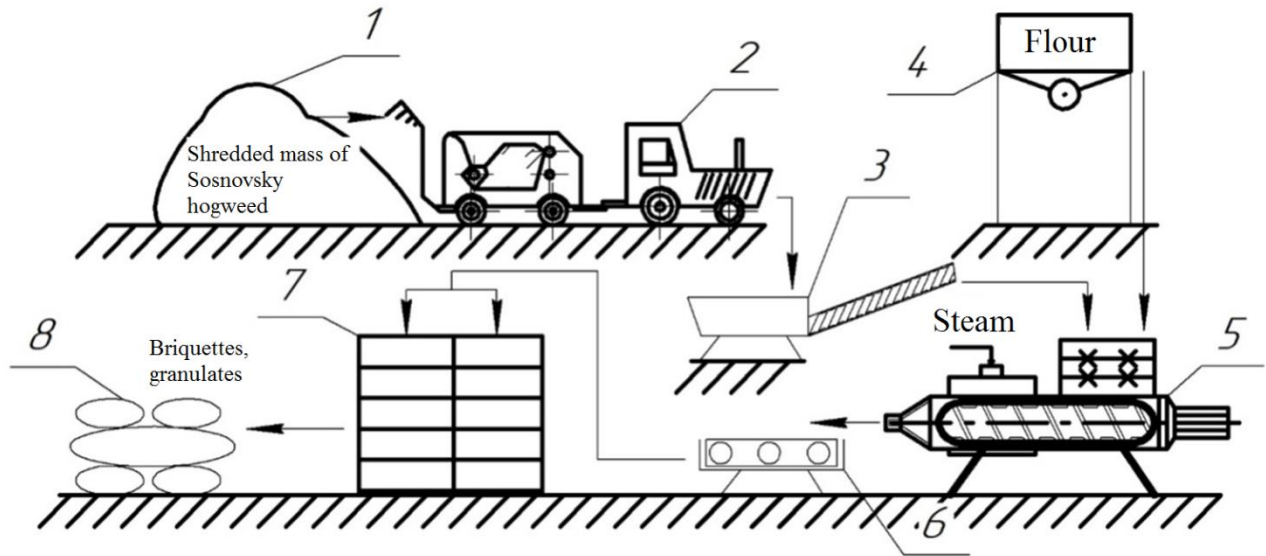

1 - stored shredded green mass of Sosnovsky hogweed; 2 - small-sized mobile multifunctional unit (SMMU); 3 - screw feeder; 4 - feeder-dispenser skim soy flour; 5 - granulator briquetting machine; 6 - tray; 7 - drying cabinet "ESPIS - 4 - universal"; 8 - packaged product.

Figure 4: Constructive-technological scheme of the line for the preparation of feed briquettes and pellets using Sosnovsky hogweed

CONCLUSION

Based on the proposed technological approaches to solving the HS disposal problem, a scheme of the production process on the use of HS in feed products in the form of pellets and briquettes is substantiated, which includes a set of successively interrelated operations on the harvesting of raw materials, its regrinding, and dosing as part of a composition with non-fat soy flour, compaction and molding.

Given this list of operations, a constructive-technological scheme has been developed and proposed, including a reasonable system of technical equipment necessary and deliverable to achieve the set goal.

Using the above formulas, the parameters of technical means for obtaining protein-carbohydrate feed additive in the form of granules and briquettes are justified.

REFERENCES

- [1] Guide for feeding farm animals / Comp. A.V. Venediktov. - M. Rosselkhozizdat, 1983. - 303 p.
- [2] Shkolnikov P.N. Improving the efficiency of the technological line of preparation and distribution of feed on small cattle farms / abstract of Diss. Cand. tech. sciences. 2016. - 23 p.
- [3] Patent of the Russian Federation №2624954 Self-loading feed dispenser / Dotsenko S.M., Shkolnikov P.N. and others. Publ. In BI No. 20 dated 07/11/2017.
- [4] A. V. Burmaga, S. M. Dotsenko, L. G Krjuchkova, and V. V Shishkin. Efficient Technologies Preparation of Feed for Pigs Based on Root Turnip Varieties Kuuziku. Research Journal of Pharmaceutical, Biological and Chemical Science. 2016;7(1):1140-1144.
- [5] S. V. Varaksin, S. M. Dotsenko, L. G. Kryuchkova, A. V. Burmaga and D. A. Mark in Theoretical substantiation parameters of the process for obtaining a soybean-grain substitute for dairy feed. Research Journal of Pharmaceutical, Biological and Chemical Sciences. 2018, March–April. P. 809-816.
- [6] S.V Varaksin, S.M. Dotsenko, A. V. Burmaga, D. A. Markin and L.G. Kryuchkova. Kinematic Aspects For Justifying The Parameters Of The Chamber-Type Tray Dryer. Research Journal of Pharmaceutical, Biological and Chemical Sciences. 2018, May–June. P. 814-818.