

Research Journal of Pharmaceutical, Biological and Chemical Sciences

Mechanical - Technological Basics Of Machine Harvesting Of Tobacco Leaves.

Evgeniy Ivanovich Vinevskiy^{1, 2*}, Evgeniy Ivanovich Trubilin², Sergey Konstantinovich Papusha², Aleksandr Vasil'yevich Ognyanik¹, and Vladimir Ivanovich Konovalov².

¹State All - Russian scientific research institute of tobacco, makhorka and tobacco products, Moscovskaya str., 42, Krasnodar 350072, Russia.

²Kuban State Agrarian University named after I.T. Trubilin, Kalinina str., 13, Krasnodar 350044, Russia.

ABSTRACT

This article presents the results of the development of a model for the functioning of the post-harvest tobacco processing process in the form of a 4-element facility with corresponding output subprocesses. The main parameters of machine technologies and operation modes of mechanization means for tobacco harvesting with the use of a multilevel system approach are optimized. A new way of accumulating transport and short-term storage of tobacco leaves in a shipping container has been developed. The parameters of the process of accumulation of tobacco leaves between surfaces of a flexible material are theoretically justified when rolling it into a roll. The parameters and operating modes of the roll storage and the working organ for its formation have been optimally optimized.

Keywords: model; tobacco; leaves; technology; systems approach; roll storage; tension.

**Corresponding author*

INTRODUCTION

In the production of tobacco raw materials, the most laborious process is its harvesting and further processing. In developed countries, harvesting is mechanized and produced by tobacco harvesters. At the same time, the accumulation and transportation of leaves is produced in heavy containers, they have a heterogeneous composition, are located chaotically, damaged, stick together and require immediate processing. Drying them is carried out in containers in bulk in artificial conditions and without sorting leads to a surplus of energy resources. The subsequent sorting of leaves increases the effort [1].

In countries with little developed economies, manual labor is mainly used. For manual cleaning, the leaves are transported in soft containers (rowers) or in containers, which are then subjected to special preparation before drying (layout, languor, polish orientation), but they are dried both in natural and artificial conditions [2, 3].

The aim of the research was to develop a mechanical and technological basis for machine cleaning of tobacco leaves.

MATERIALS AND METHODS

Experimental studies on the development of mechanical and technological foundations for machine cleaning of tobacco leaves were carried out in accordance with existing methods and standards for research and testing of technologies and mechanization tools for harvesting tobacco leaves [4].

RESULTS AND DISCUSSION

Development of a model for the functioning of the post-harvest tobacco processing process

In the production of tobacco, in contrast to post-harvest processing of other crops, the time gap between harvesting and the beginning of further processing should not exceed 4-8 hours [5, 6].

A model for the functioning of the post-harvest tobacco processing process is developed, which can be represented as a 4-element object with corresponding output subprocesses F_{PYT} (figure 1).

$$F_{PYT} = \{ F_1, F_2, F_3, F_4 \}$$

The main output variables for the tobacco preparation subprocess F_1 can take the yield of freshly harvested tobacco $Y_{mi}(t)$ and the state of the plant mass $Kp_i(t)$.

$$F_1 = \{ Y_{mi}(t), Kp_i(t) \}$$

At the output of the tobacco leaf harvesting subprocess, we have the n-th number of vector functions F_2 , equal to the number of broken tobacco leaves. Their components are the amount of freshly harvested tobacco $Yp_{ci}(t)$ and his condition $K_{ci}(t)$. In addition, as a result of the subprocess of machine harvesting of tobacco leaves, there will be loss of freshly harvested leaves $H_{fi}(t)$.

$$F_2 = \{ Yp_{ci}(t), K_{ci}(t), H_{fi}(t) \}$$

The peculiarity of obtaining tobacco raw materials is that the output elements of the leaf-cleaning sub-process are simultaneously input elements of the sub-process for their drying. Output vector function F_3 drying sub-process includes the amount of unfermented leaves $Yp_{hi}(t)$, their quality $K_{hi}(t)$ and loss $H_{ni}(t)$:

$$F_3 = \{ Yp_{hi}(t), K_{hi}(t), H_{ni}(t) \}$$

The fourth subprocess of post-harvest processing of tobacco is its fermentation. Output vector function F_4 tobacco leaf fermentation sub-process includes the amount of fermented tobacco leaves $Yp_f(t)$, their quality $K_f(t)$ and loss $H_f(t)$:

$$F_4 = \{Y_{p_f}(t), K_f(t), H_f(t)\}$$

The main provisions of a multilevel system approach to optimizing the parameters of machine technologies for harvesting tobacco leaves

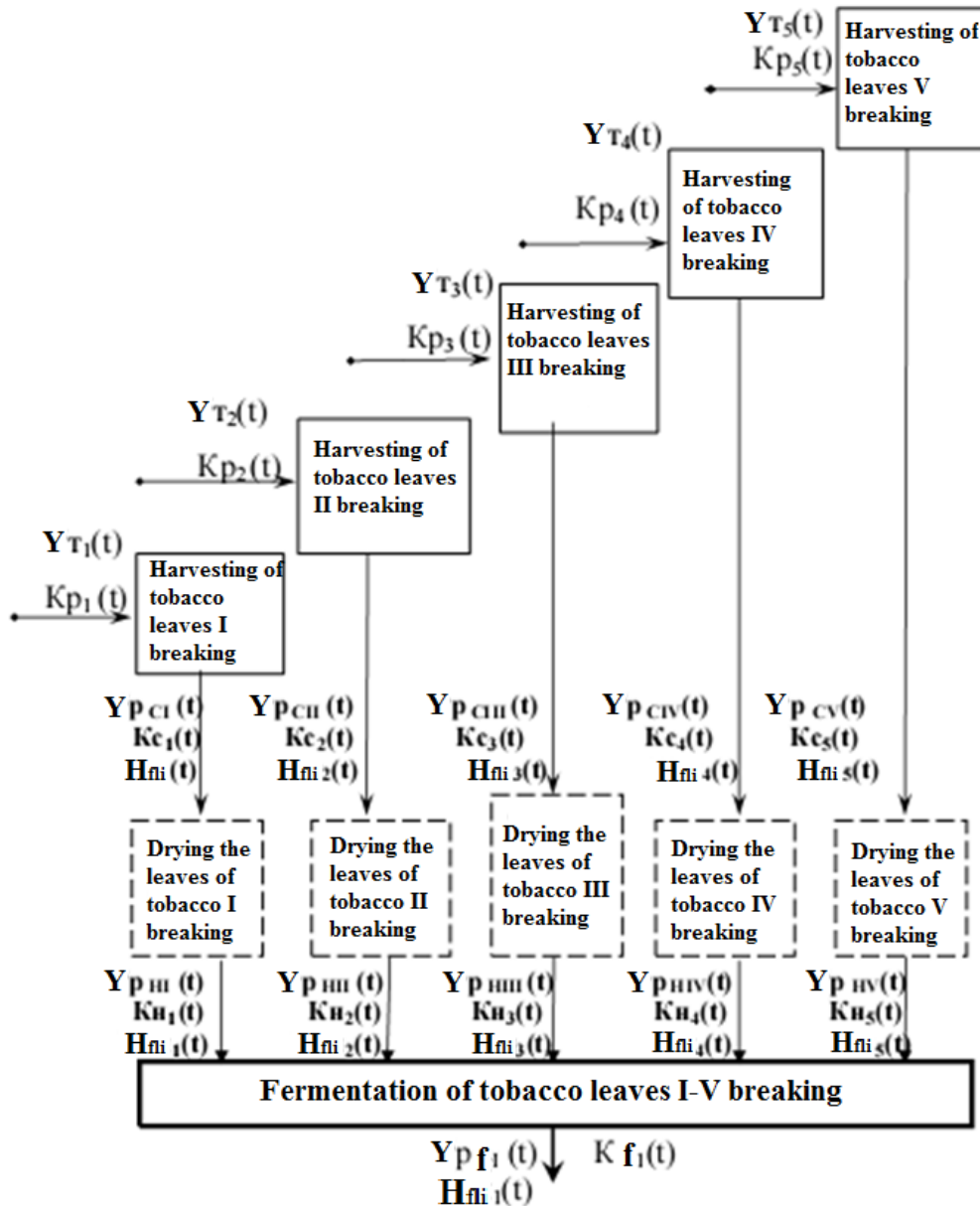

$Y_{T_i}(t)$ – yield of freshly harvested tobacco; $K_{p_i}(t)$ – plant condition; $Y_{p_{c_i}}(t)$ – freshly harvested tobacco; $K_{c_i}(t)$ – condition of freshly harvested tobacco; $H_{fi_i}(t)$ – loss of freshly harvested tobacco; $Y_{p_{u_i}}(t)$ – amount of unfermented tobacco; $K_{u_i}(t)$ - quality of unfermented tobacco; $H_{fi_i}(t)$ - loss of unfermented tobacco $Y_{p_f}(t)$ - amount of fermented tobacco; $K_f(t)$ – quality of fermented tobacco; $H_f(t)$ – loss of fermented tobacco.

Figure 1: Model of the functioning of the technological process of harvesting and post-harvest treatment of tobacco

The main provisions of a multilevel system approach to optimizing the parameters of machine technologies and modes of operation of mechanization means for tobacco harvesting are developed.

The goal of optimizing the parameters of the machine technology of harvesting and processing tobacco was to ensure the required quality of work and maximum productivity of technological equipment and

mechanization means with the least expenditure of resources used. To solve it, a multi-level system approach is applied. Algorithm for multi-level solution of optimization problems of machine technology of tobacco harvesting and processing is presented in Figure 2. Optimization tasks at each level were formed in such a way that the output parameters of optimization problems of previous levels were the initial data for subsequent levels.

The first level of optimization Y₁ - selection and justification of the parameters of machine technology. At this level, only energy-saving principles for influencing the tobacco crop were selected when performing individual operations. The optimization criteria were the sum of technological energy inputs per unit of yield $E_T \sum u$ and per unit area $E_T \sum F$, as well as the completeness of leaf separation and their damage. The result of optimization was the method of separating the tobacco leaf from the stem $C_{secession}$.

The energy costs necessary to separate a single tobacco leaf were determined on the basis of previous experimental studies. The calculation of the necessary energy consumption for the separation of leaves from one plant and the technological energy consumption per unit area were determined by formulas (1) and (2) and are presented below.

To separate leaves from one plant, the necessary energy costs are equal

$$E_{plant\ i} = E_{sep.\ iv.} \times n_{leaves\ j} \quad (1)$$

where $E_{plant\ i}$ - necessary energy expenditure for the separation of leaves from one plant, J;
 $n_{leaves\ j}$ - number of leaves harvested from one plant in one pass of the equipment according to the i-th harvesting technology.

Technological energy costs per unit area were determined by the formula

$$E_{sep./ha} = \frac{0,981 \times P_{sep.lv.} \times S_{pet.} \times n_{leaves\ j} \times k_{passes\ j} \times m_{plant\ j}}{1000} \quad (2)$$

where $k_{passes\ j}$ - number of passes of the technical means on the field according to the i-th technology;
 $m_{plant\ j}$ - number of tobacco plants on the field according to the i-th technology.

It has been established that the energy consumption for separating the leaves from below is upwards lower than in the separation of tobacco leaves from top to bottom by 1.8 ... 1.82 times.

Second level of optimization Y₂ provided for the substantiation of the most important parameters of the machine technology and operating modes of the technical means. The initial input data were the results of optimization of the first level. The optimization criteria were the resulted operating costs C_{oc} and productivity of technical means W_{tm} .

The influence of working speed of technical means for tobacco harvesting on operating costs with combined technology of tobacco harvesting is determined (Figure 3). It is established that, the minimum speed of movement of the technical means for tobacco harvesting should be more than 1.8 km / h.

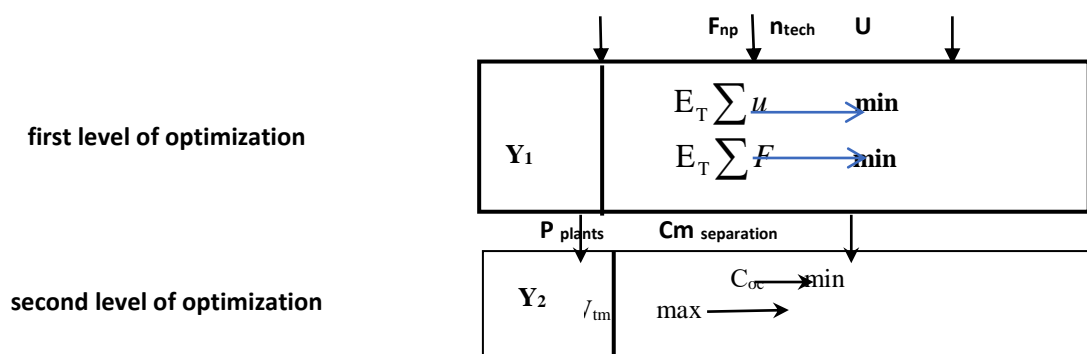

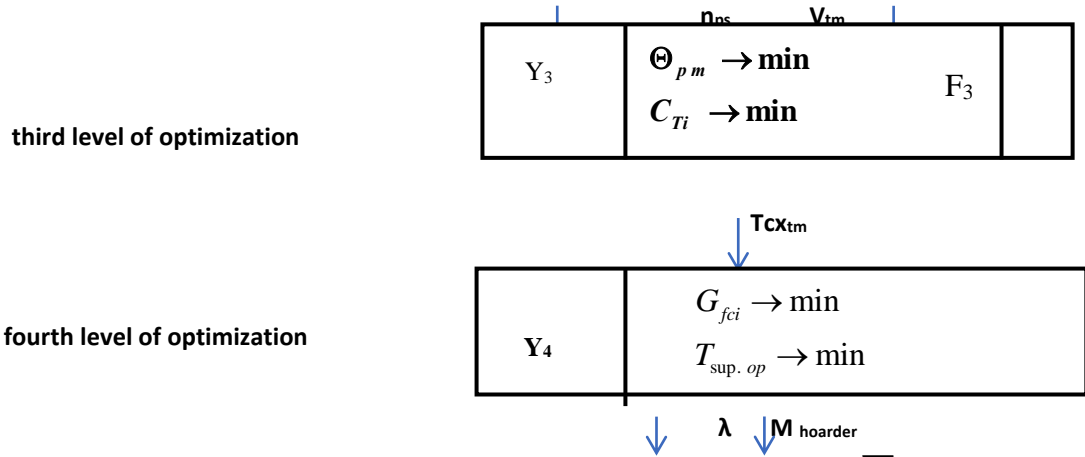

F_{np} – natural factors of production; n_{tech} – number of technologies; U_j – planned yield; $E_T \sum u$ – amount of technological energy consumption per unit of yield; $E_T \sum F$ – amount of technological energy consumption per unit area; P_{plants} – plant parameters; $Cm_{separation}$ – method of separating the tobacco leaf from the stem; C_{oc} – reduced operating costs; W_{tm} – technical productivity; n_{ps} – number of passes of technical means; V_{tm} – operating speed of the technical means; Θ_{pm} – specific fuel consumption; C_{Ti} – reduction in the cost of tobacco raw materials; F_3 – introduction of a new technological operation; TcX_{tm} – technological scheme of technical means for tobacco harvesting; G_{fci} – fuel consumption of idling; $T_{sup.op}$ – auxiliary operations time; λ – distribution coefficient of regulatory reactions; $M_{hoarder}$ – optimum hoarder capacity.

Figure 2: Algorithm for multi-level optimization of machine technology parameters and operating modes of technical means

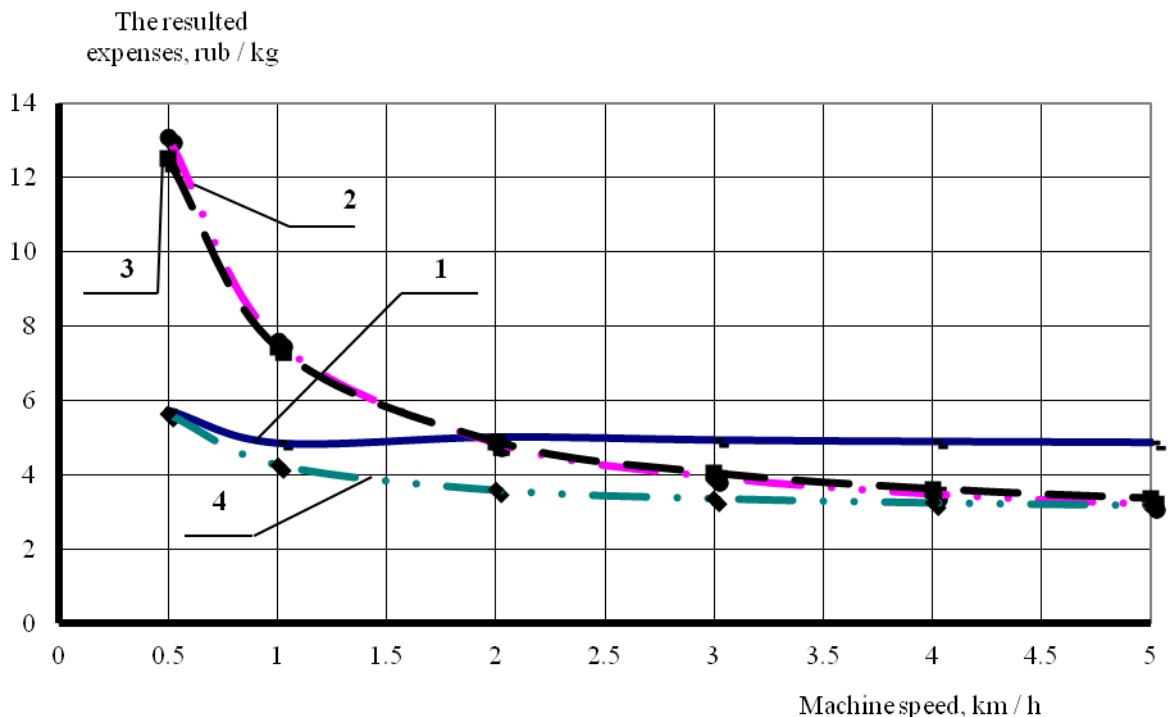

1 - manual harvesting for 5 passes; 2 - combined harvesting for 5 passes; 3 - combined harvesting for 3 passes; combined harvest for 2 passes.

Figure 3: Effect of the speed of the technical means for tobacco harvesting on operating costs

At the third level of optimization Y_3 The technological and layout scheme of the technical means for tobacco harvesting was justified. Criteria for optimization are the reduction of the cost of tobacco raw materials C_{Ti} with machine cleaning technology and specific fuel consumption $\Theta_{\text{fuel consumption}}$.

An improved technological scheme of the technical means for tobacco harvesting has been developed, including a new technological method - separation (separation) according to the degree of their mechanical damage (Figure 4) [7].

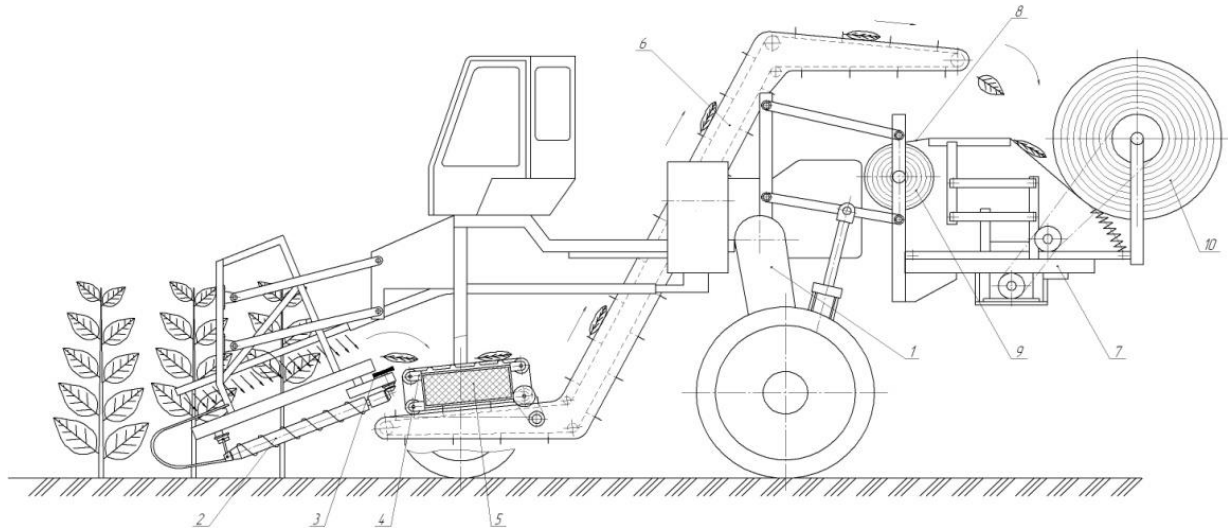

1 - self-propelled chassis; 2, 3 - separating mechanism; 4 - separation device; 5 - container for fine fraction; 6 - remote conveyor; 7, 8, 9, 10-roll storage.

Figure 4: Improved technological scheme of the technical means for harvesting tobacco leaves

A rational layout scheme of a technical tool for tobacco harvesting was conducted, based on the capacity N_f and fuel consumption G_{tf} distribution coefficient of regulatory reactions λ (Table 1 1).

Table 1: Technical and operational indicators of technical means for tobacco harvesting of different layout schemes

Name of the layout scheme	Coefficient of distribution of regulatory reactions λ	Power costs N_f , kW	Fuel consumption G_{tf} , kg / h
Longitudinally	0,31	3,96	1,97
Cross	0,67	4,45	2,07

Thus, it is justified that the technical means for tobacco harvesting should have a longitudinally straight flow layout.

Fourth level of optimization Y_4 used to justify the capacity of the hoarder of tobacco leaves M_{hoarder} . Criteria for optimization appeared technical means W_{tm} and fuel consumption $\Theta_{\text{fuel consumption}}$. Determination of the optimum capacity of the accumulator of tobacco leaves was carried out, proceeding from the conditions of maximum operational productivity of the technical means $W(\text{kg} / \text{h})$ (Figure 5).

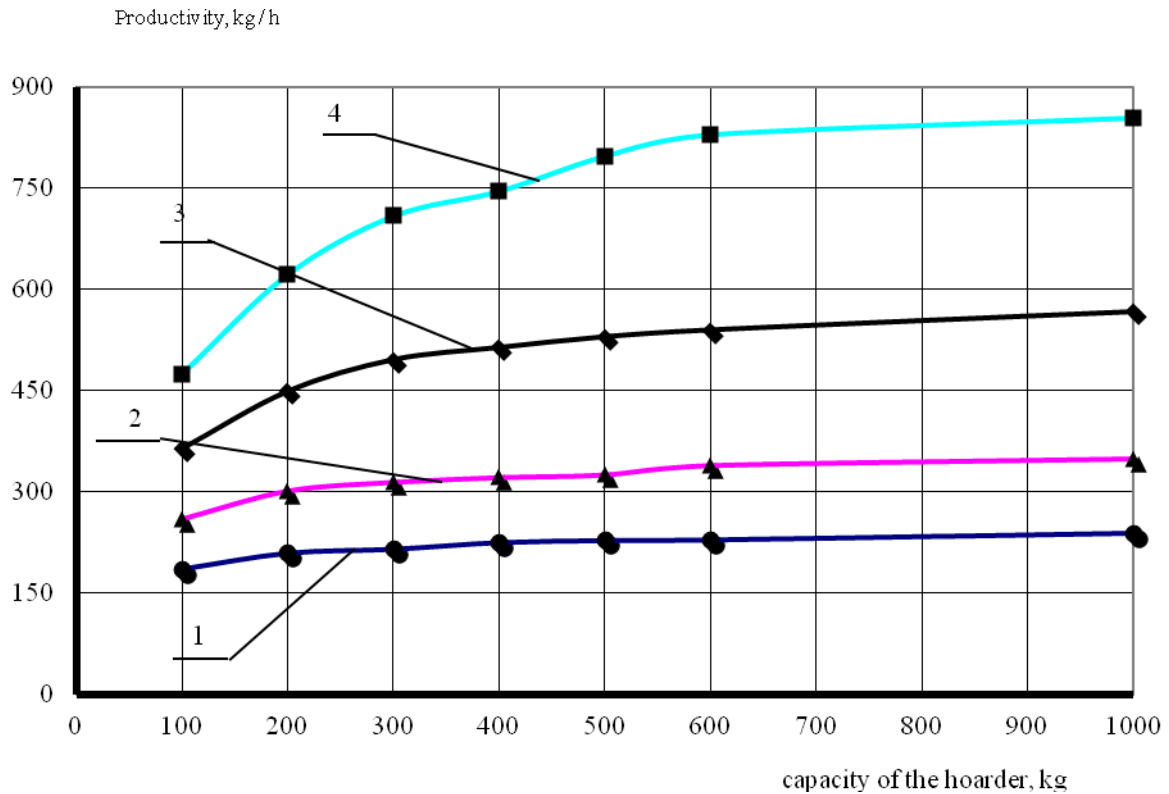

1 - the first (fifth) breaking; 2 - second breaking; 3 - the third breaking; 4 - fourth breaking.

Figure 5 - Graphs of the dependencies of the productivity of the technical means for harvesting tobacco from the storage capacity of the hoarder

A new way to store, transport and short-term storage of freshly picked tobacco leaves in a shipping container

To reduce labor and energy costs for post-harvest treatment of tobacco leaves, a new method for their accumulation, transportation and short-term storage in a shipping container was developed [8]. Its essence lies in the formation of a roll with leaves between the surfaces of a flexible air-permeable material that has hygroscopic properties. The method is adapted both for manual and for machine harvesting of tobacco.

As a working hypothesis it was accepted that the reduction of energy and labor costs for drying can be achieved by using the method of accumulation and transportation of leaves into a roll-type storage device, which allows to reduce the moisture content of the leaves and mechanize the unloading process. The technological scheme for the formation of a roll-type accumulator is shown in Figure 6.

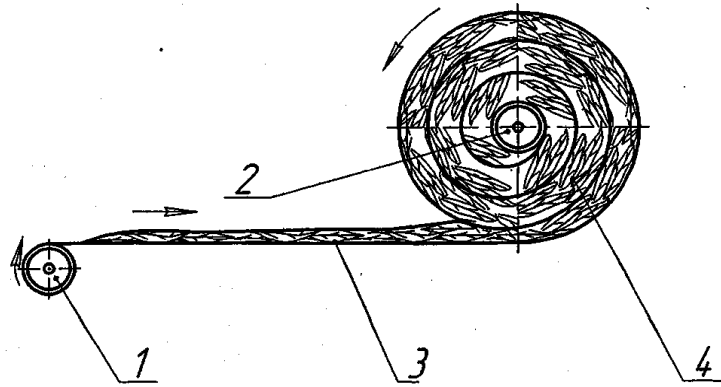

1 - feeding drum; 2 - a receiving drum; 3 - material of the accumulator; 4 - roll with leaves

Figure 6: Technological scheme for the formation of a roll-type hoarder

When transporting and short-term storage in a roll, the freshly picked tobacco leaf undergoes a preliminary technological treatment in the form of partial drying and languishing. Leaves located between the surfaces of the tape drive do not stick together, do not hurt and give off moisture due to the hygroscopicity of the tape material and the porosity of the roll itself. Contact mass transfer occurs by moving the fluid from the body with a large potential for moisture transfer (tobacco leaf) to the body with a smaller transfer potential (roll material).

When preparing for drying, the leaves from the roll are unloaded by rewinding the tape of the roll and fed to the line of polishing cleavage and orientation.

The parameters of the process of accumulation of tobacco leaves between surfaces of a flexible material are theoretically justified when it is rolled into a roll [9]. Modeling the process of accumulation of leaves between the surfaces of a flexible material when winding it into a roll showed that the accumulation and fixation of leaves between the surfaces of the material is carried out under the condition that frictional forces arise between them as a result of stretching its branches (Figure 7). The frictional force distributed within the girth arc depends on the amount of tension of the ends of the material \bar{T}_1 and \bar{T}_2 , arc girth α and the coefficients of friction between the surfaces of the material f_{mat} and between the material and the leaves f_{tob} .

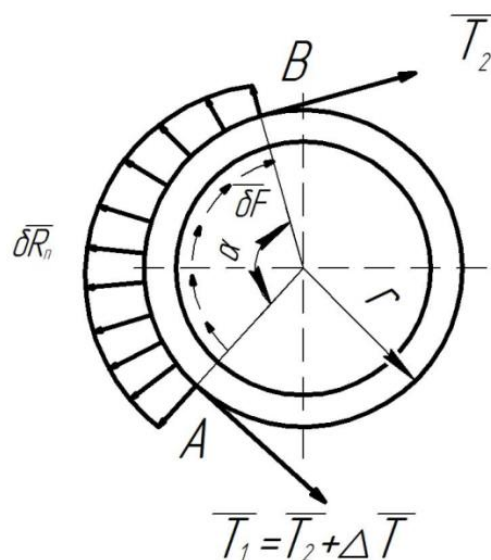

Figure 7: Scheme of interaction of flexible material with tobacco leaf

Difference in tensile forces \bar{T}_1 and \bar{T}_2 depends on the amount of frictional forces acting on the material side on the tobacco sheet located between the surfaces of the material within the arc of the girth α . To establish the connection between forces \bar{T}_1 and \bar{T}_2 we select a small arc of material by applying tensile forces to its ends \bar{T}_2 and $\bar{T}_1 = \bar{T}_2 + \Delta\bar{T}$, each of them is directed along the tangent to the drum at the corresponding point. In the section AB, the tension force is not constant and varies from the value \bar{T}_1 at point A to the value \bar{T}_2 at point B. Pressing a flexible material will be greater at point A. From the drum side, a normal distributed pressure acts on the selected element of matter, having a resultant $\delta\bar{R}_n$, and the distributed frictional force $\delta\bar{F}$, directed against the sliding speed and according to the law of sliding friction $\delta\bar{F} = f\delta\bar{R}_n$.

Let us compose the equation of uniform sliding of a flexible material along an arc of girth for a flexible coupling element of length dl , corresponding to an elementary angle of girth $d\alpha$ in the direction of the Y axis (Figure 8).

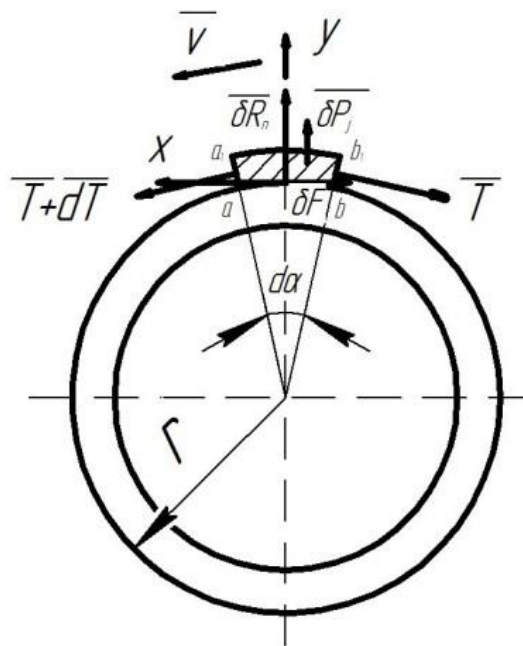

Figure 8: Diagram of flexible air-permeable material

In cross sections aa and bb are tension \bar{T} and $\bar{T} + dT$, elementary frictional force $\delta\bar{F}$ and normal reaction $\delta\bar{R}_n$.

From the condition of equilibrium of the sum of the forces on the axis $\sum Y = 0$ we get

$$-(\bar{T} + d\bar{T}) \sin \frac{d\alpha}{2} - \bar{T} \sin \frac{d\alpha}{2} + \delta\bar{P}_j + \delta\bar{R}_n = 0 \quad (3)$$

Replacing $\sin \frac{d\alpha}{2}$ on $\frac{d\alpha}{2}$ and neglecting a small quantity $\frac{d\bar{T}d\alpha}{2}$, we get

$$\delta \bar{R}_n = \bar{T} d\alpha - \delta \bar{P}_j \tag{4}$$

Differential relationship indicates that pressing $\delta \bar{R}_n$ material to the curved surface is caused by tension \bar{T} and the curvature of the surface (angle- $d\alpha$), with the centrifugal force \bar{P}_j reduces this pressing.

Converting, we get

$$\delta \bar{R}_n = \left(\bar{T} - \frac{\bar{P}_{mat} \bar{V}_{mat}^2}{g} \right) d\alpha \tag{5}$$

It follows from equation (3) that there is no compression in two cases:

if $d\alpha = 0$; and if $\bar{T} - \frac{\bar{P}_{mat} \bar{V}_{mat}^2}{g} = 0$

$$\bar{T} = \frac{\bar{P}_{mat} \bar{V}_{mat}^2}{g} \tag{6}$$

where \bar{T} - tension from centrifugal forces, H.

From equation (6), the rate of material transfer is determined

$$V_{cr} = \sqrt{\frac{g \bar{T}}{\bar{P}_{mat}}} \tag{7}$$

where V_{cr} – critical speed of material movement, m / s.

As a result of theoretical studies of the process of accumulation of leaves between surfaces of a flexible material, equations were obtained for calculating the critical velocity and the normally distributed pressure on them.

Technological studies on the temporary storage of leaves in a roll-type storage device during its transportation and preparation for drying have been carried out. It has been established that the shelf life of leaves in it without ventilation is limited to 2.5 days, over which the parking begins (the level of thermal denaturation $t = 35-40$ °C). The graph of temperature distribution at points that depend on the radius of the roll R is shown in Figure 9.

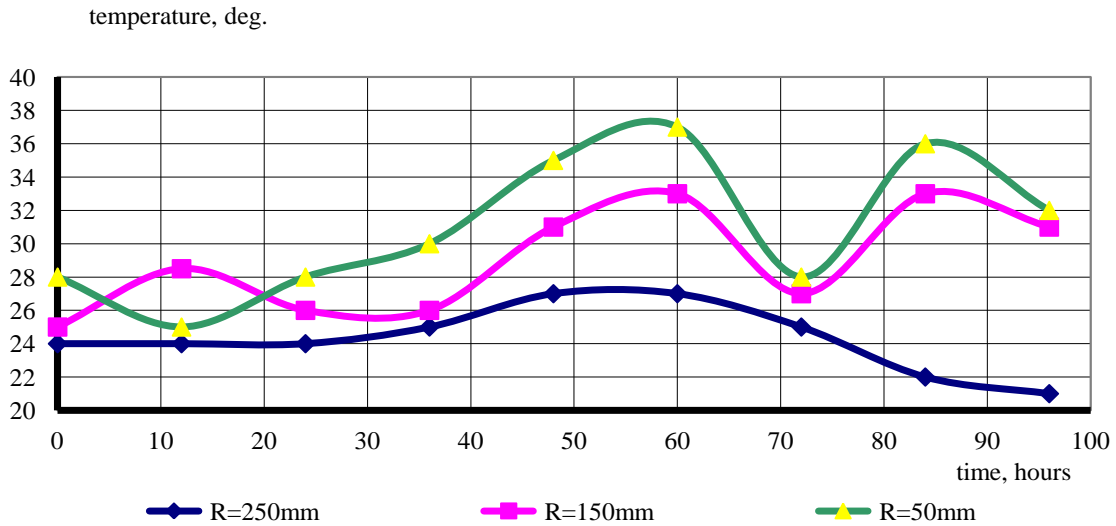

Figure 9: Dynamics of temperature distribution in a roll-type hoarder, depending on its radius

It was found that the density of the roll should not be more than 250 kg / m³ and the initial moisture content of the leaves - no more than 88%. If these conditions are met, qualitative indicators of tobacco raw materials are ensured, which is confirmed by studies:

- trade quality in accordance with GOST 8073-77: 1st grade-72.4%, 2nd grade-15.8%, 3rd grade-11.8%;
- chemical composition: nicotine - 0,9 mg / cigarette; carbohydrates - 13.1%; proteins - 5.0%, Schmuck's number -2.6.

A high carbohydrate-protein ratio of 2.6 (Schmuck's number) proves the positive effect of short-term storage of leaves in a roll-up storage container, where the process of frying is carried out with a slight oxygen starvation of leaves under favorable heat and humidity conditions.

Advantage of the proposed process of accumulation and transportation of leaves in a roll-type storage device is that the sheet, being in a roll, during transportation and short-term storage, languishes in the created heat and moisture conditions inside it, that is, it undergoes a preliminary technological treatment in which, with a lack of oxygen, certain chemical processes in the leaves, the leaf becomes yellow and loses moisture. Loss of moisture reduces the moisture content of the leaves, which reduces the drying time spent in subsequent stages of their post-harvest treatment.

The reduced tiger stump with the use of the tape of the accumulator in the length of the sheet promotes their better piercing with the needle of the tobacco-sewing machine, they are less fragile, therefore, they are fixed more qualitatively on the cord and exclude the loss of leaves.

The main parameters of the technological process of accumulation of freshly harvested tobacco leaves in a roll-up storage device have been optimally optimized, depending on the specific load of tobacco leaves per unit area of the material.

In order to determine the efficiency of short-term storage of tobacco leaves in a roll stock, when preparing for drying, the concept of the coefficient of relative moisture loss is introduced, which is the ratio of the relative loss of moisture of the investigated leaves in a roll storage to the loss of control moisture, freely poured leaves in open containers:

$$k_{is} = \frac{\Delta m_{exp}}{\Delta m_{contr}} \tag{8}$$

where Δm_{exp} - relative loss of moisture of the sample, %;

Δm_{contr} - relative loss of moisture in the control sample, %.

To characterize the studied moisture-permeable materials of a roll storage device, the concept of a porosity coefficient of a material k_{por} , which is the ratio of the area of the lumen cell to the area of the cell, taking into account the thickness of its walls.

$$k_{por} = \frac{L^2}{(L+S)^2} \tag{9}$$

where L – cell size of air-permeable material;
S – wall thickness of air-permeable material.

The main parameters of the technological process of leaf storage in a roll-type storage device have been optimized on the basis of analysis of the second-order regression equation obtained during the realization of the three-factor experiment. As a criterion of optimization, the coefficient of relative loss of moisture k_{ls} . (Y) is adopted. Various factors affecting this index were considered [10].

It is established that the main factors are: the number of leaves in a pack n_{layer} (X_1), force of tension of material P_{mat} (X_2) and the porosity of the material k_{por} (X_3). The regression equation has the form

$$k_{ls} = 1,3379 - 0,477 X_1 + 0,1884X_2 + 0,2372X_3 + 0,339X_1^2 - 0,051X_2^2 - 0,225 X_3^2 - 0,166 X_1 X_3 + 0,0963 X_2 X_3 \tag{10}$$

To determine the optimal values of factors X_1, X_2, X_3 , a graphical method is applied and contour curves of equal output are obtained (Figure 10).

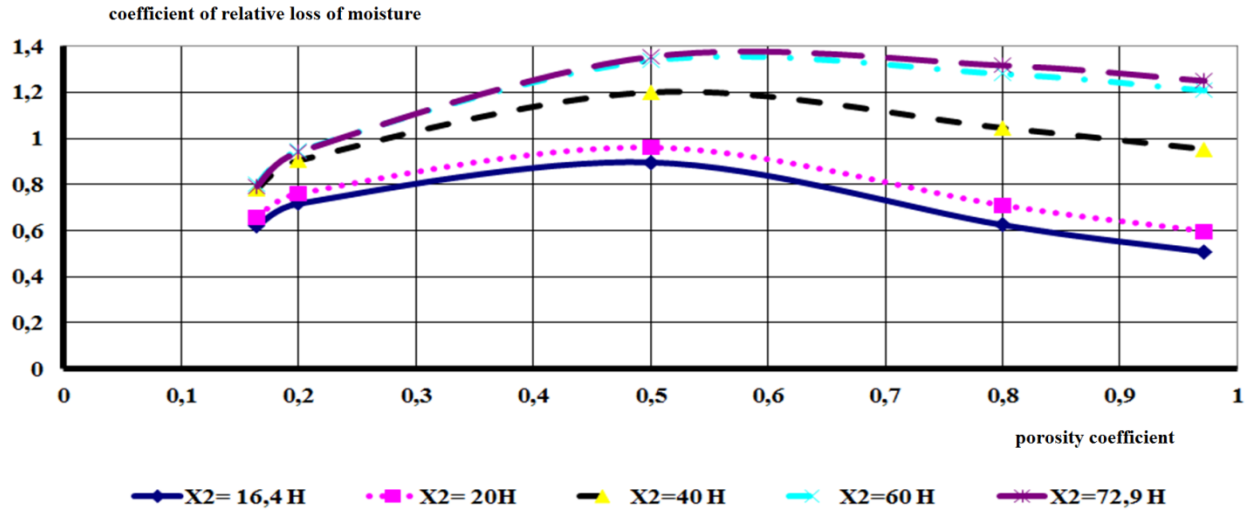

Figure 10: Outline curves of equal output

The influence of the main factors influencing the loss of moisture during transportation and storage of leaves in a roll is confirmed: the number of leaves in a pack n_{layer} (X_1); force of tension of material P_{mat} (X_2) and the porosity of the material k_{por} (X_3). When optimizing the parameters, the following values are revealed: $n_{layer}= 1...5$; $P_{mat}= 60...72,9 H$; $k_{por}= 0,2... 0,4$.

Transportation of rolls is made by any vehicle with any laying, it is better with the orientation of the sheet along the movement, to create a blow-off when counter-current air during transport. Leaves in rolls do not stick together, the packs do not deform, and a small pre-press when applying rolls gives a more significant decrease in moisture, which is confirmed by experimental data.

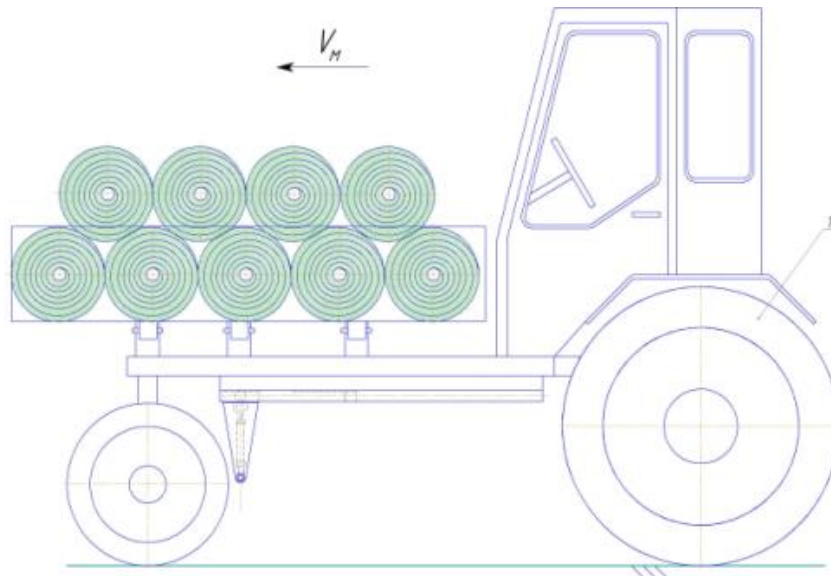

Figure 11: Technological scheme of the transportation of leaves in a roll-type accumulator

CONCLUSION

The development of the mechanical and technological foundations for machine cleaning of tobacco leaves made it possible to establish the following:

1. It is determined that the most expedient is the principle of separation of the leaf from the stem - "bottom-up".
2. It has been established that the minimum speed of movement of the technical means for tobacco harvesting should be more than 1.8 km / h.
3. An advanced technological scheme of the technical means for tobacco harvesting has been developed, which includes a new technological method - separation according to the degree of their mechanical damage.
4. The layout of the technical means for tobacco harvesting should be longitudinal-straight-through.
5. A new method for the accumulation, transport and short-term storage of freshly harvested tobacco leaves in a shipping container has been developed.
6. The optimum capacity of a roll-type accumulator of a leaf type of tobacco leaves should be 500-700 kg.

REFERENCES

- [1] Mokhnachev, I.G. Technology of drying and fermentation of tobacco. Mokhnachev, M.G. Zagoruiko, A.I. Petrius. - Moscow: Kolos, 1993. - 280 p.
- [2] Salomatin V.A. Perspectives of innovative development of tobacco growing in Russia. - Krasnodar: KGUKI, 2010. - 128 p.
- [3] Ulyanchenko E.E. Technological equipment and means of mechanization for cleaning and post-harvest processing of tobacco by the firm "DE CLOET" // Innovative research and development for the scientific provision of production and storage of environmentally safe agricultural and food products: mater. Intern. scientific-practical. Conf. (April 06-26, 2015, Krasnodar). - p. 271 - 276 URL: http://vniitti.ru/conf/conf2015/sbornik_conf2015.pdf.
- [4] OST 10 8.16-2002 "Testing of agricultural machinery. Machines for cleaning tobacco and tobacco. Methods for assessing performance indicators».
- [5] Leonov, I.P. Textbook of the tobacco grower / I.P. Leonov, A.G. Petrenko, G.M. Psarev. - M.: Agropromizdat, 1986. - 288p.
- [6] Trubilin, E.I. Mechanic and technological foundations of machine cleaning and processing of tobacco / E.I. Trubilin, E.I. Vinevsky // Proceedings of the Kuban State Agrarian University / Krasnodar: 2015. - Vol. No. 1 (52). - P.244 - 249.



- [7] Vinevskaya, N.N. Improvement of the technological process of machine cleaning of tobacco / N.N. Vinevskaya // Mechanization and electrification of agriculture - 2011 - №1 - P. 8-11.
- [8] Vinevskaya, N.N. Optimization of parameters and operating modes of working organs for accumulation and transportation of tobacco leaves for machine cleaning / the abstract of the thesis for obtaining the scientific degree of candidate of technical sciences, Krasnodar, 2016, 24p.
- [9] Vinevsky, E.I. Optimization of parameters of the technology of transporting tobacco leaves in a roll-type accumulator / E.I. Vinevsky, N.N. Vinevskaya // News of Higher Educational Institutions, Food Technology, 2015, No. 1. - P. 102-106.
- [10] Ognianik, A.V. Theoretical and experimental optimization of parameters of working organs for preparation of tobacco leaves for drying / A.V. Ognianik // Scientific Journal of KubSAU [Electronic resource] .- Krasnodar: KubGAU, 2011. - No. 09 (73). - 7 p. - Access mode: <http://ej.kubagro.ru/2011/09/pdf/36.pdf>.