

# Research Journal of Pharmaceutical, Biological and Chemical Sciences

## Corrosion Protection Study for Carbon Steel 1045 in Saline Water Using Nanocomposite by Spin Coating as protective coating.

Ahlan M Farhan<sup>1</sup>, Nafeesa J Kadhim<sup>1\*</sup>, Aqeel F Hasan<sup>2</sup>, and Harith I Jaafer<sup>3</sup>.

<sup>1</sup>Department of Chemistry/ College of Science for Woman/ University of Baghdad, Iraq.

<sup>2</sup>Ministry of Science and Technology.

<sup>3</sup>Department of Physics/ College of Science / University of Baghdad, Iraq.

### ABSTRACT

The aim of the work is to report the corrosion protection aspects of Nan composite and Epoxy coating on Carbon Steel (1045) in Saline water (3.5% NaCl) over range temperature (298-328) K using potentiostatic and Electrochemical Impedance Spectroscopy Methods. Spin coating technique was used for the coating purpose. Nano magnetite  $Fe_3O_4$  and Epoxy were deposited on the steel substrate as composite. The films were characterized by Scanning Electron Microscopy (SEM) which shows the homogeneity and amount of porosity in the coating. The corrosion rate is found to decrease from 53 mpy for Carbon steel (1045) to 23 mpy for Epoxy coating. Also, the corrosion rate is found to decrease to 0.6 mpy for Nano composite coating. Change in the enthalpy of activation & entropy of activation were evaluated. Apparent energies of activation have been calculated for Corrosion process of Coated and Uncoated and C.S45 via Spin Coating technique in saline water (3.5% NaCl). The results presented are the evidence of the influence of Nano Magnetite  $Fe_3O_4$  coatings on corrosion protection of Carbon Steel. Electrochemical Impedance Spectroscopy and Potentiostatic Polarization studies confirmed that the sample with Nan composite coating is most resistant to corrosion when compared with Epoxy Coating

**Keyword:** Spin Coating, Magnetite, Epoxy, Nan composite, Corrosion, Electrochemical Impedance.

*\*Corresponding author*

**INTRODUCTION**

Corrosion can be defined as an electrochemical phenomenon. Moreover, it associated with the flow of electrical current and their degradation of materials. Structures is one of the significant issues that leads to the devaluation of the goods investment [1]. Carbon steel is most widely used engineering material, accounts for approximately 88% of the annual steel production in world wide. Despite its relatively limited corrosion resistance Carbon Steel used in large tonnages in marine applications, nuclear power and fossil fuel power plants- transportation- chemical processing petroleum production and refining pipelines. Mining-construction and metal-processing equipment. Because of Carbon Steels represent largest single class of alloys in use both in terms of tonnage and total cost: it is easy to understand that corrosion of carbon steel is problem of enormous practical importance. Five different main principles can be used to prevent corrosion: appropriate materials selection, change of Environment, suitable design, application of coatings, electrochemical i.e. cathodic and anodic protection [2]. A new generation of anticorrosion materials that bath possesses passive matrix functionality and actively responds to changes in the local environment has prompted great interest from material scientists. The nanometer scaled materials have gained much attention due primarily to the novel properties induced by their high surface-to-volume ratio. Iron oxide nanoparticles and composites attracted great attention to use as protective coatings and anticorrosive materials. The roles of the magnetite particles in the polymer matrix composite are to obtain active protection to corrosive processes, to increase the barrier properties for a longer time and to decrease the penetration of aggressive species that promote corrosion when the coated metal is exposed to corrosive environment[3]. Polymer coatings are utilized to protect Steel from corrosion by giving physical blocking agent between Steel surface and corrosive environment[4], Epoxy resins possesses excellent characteristic property of corrosion resistance[5] they has been used widely as a coating material to protect reinforcement of Steel in concrete structures because of its outstanding process ability excellent chemical resistance good electrical insulating properties, and strong adhesion affinity to heterogeneous materials, Epoxy coatings generally reduce the corrosion of a metallic substrate subject to an electrolyte in two method First they act a physical barrier layer to control the ingress of deleterious species Secondly they can serve as a reservoir for corrosion inhibitors to help steel surface in resisting attack by aggressive species such as chloride anions[6]. Electro Chemical Impedance Spectroscopy (EIS) has several advantages in comparison with other electrochemical techniques. It is a non-destructive method for the evaluation of a wide range of materials, like coatings, anodized films, and corrosion inhibitors. It can provide detailed information of the systems under examination; detection and parameters of localized corrosion. Polymer based coatings use barrier technology to protect substrates against corrosive chemicals and environments, especially when in immersion service [7]. this paper reports, results of an investigation of the corrosion resistance of the Nan composite and Epoxy coatings using EIS techniques. Aim of work is applying Nanomaterials, Magnetite Fe<sub>3</sub>O<sub>4</sub> with Epoxy as a coating layer by spin coating technique for protection carbon steel from corrosion in saline water. Nyquist plot and Equivalent Circuit has been analyzed for the prediction of corrosion performance of Nan composite and Epoxy coatings SEM analysis of specimen has been performed.

**EXPERIMENTAL**

**Materials Preparation of Specimen for Testing**

The substrate used for applying the projection coating by spin coating was (Carbon Steel 1045). the chemical composition of the substrate material is presented in (Table 1). Specimens with dimensions of approximately (1.5 mm thickness and 2.5 cm in diameter). The samples of alloy have been pre treated prior to experiments via grinding with emery paper SiC (120, 240, 320, 600, 800, 1200 and 2000) to a mirror finish, followed by ultrasonic cleaning for 15min with acetone, and then washed by distilled water. The specimen was kept in desiccators for protection and preventing them from oxidation by atmospheric air and moisture before used synthesized sea water. The sea water Solution is prepared by dissolved 35g NaCl in 1L distilled water.

**Table 1: Chemical material composition for Cs45 used in this study.**

Elements	C%	Ni%	P%	S%	Cr%	Cu%	Mo%	Mn%	Fe%
Wt %	0.43-0.50	0.4	0.05	0.05	0.12	0.13	0.19	0.76	97.11

The coating material used Iron Oxide Magnetite Nano particle (30-40) nm –USA and Epoxy resin matrix was (Exit 50 KI) manufactured by Egyptian Swiss chemical industries company and formulated amine hardener mixed at a ratio (1:3).

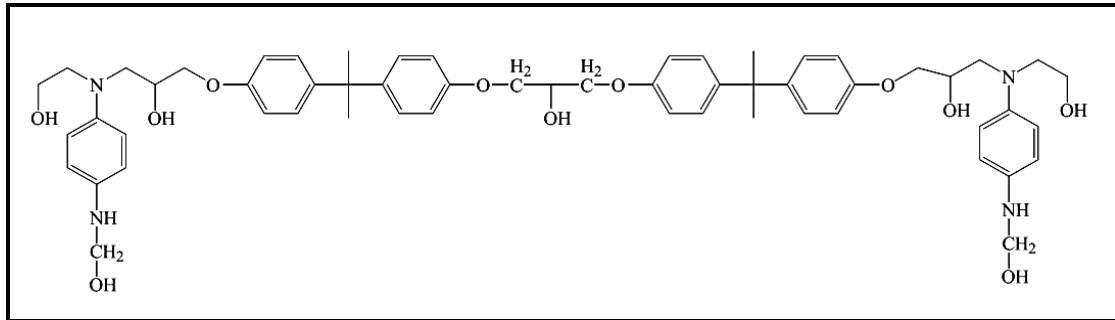

**Figure 1: Structure of epoxy with hardener**

To prepare the Nan composite the samples, EP 50 KI was mixed with Fe<sub>3</sub>O<sub>4</sub> NPs in Five different concentrations (1, 3, 5, 7 & 9 %) W/W% by using ultrasonic homogenizer processor.

**Methods: Spin Coating Technique**

During the course of this work, as spin coating device was manufactured to perform spin coating of carbon steel with different composite material. The spin coating apparatus is characterized by the following:

1. Speed revolution control (1000-3000 rpm).
2. Time Speed reader (1-60min).
3. Diameter of disk rotation (100mm).
4. Fixing the specimen by vacuum.
5. Plastic and glass cover for operation safety.
6. Motor (220V, 2000 W).
7. Chamber of spin coating with dimension 40×40×30 cm.

The spin coating formation of a thin, uniform layer of liquid on a flat rotating disk by centrifugal force is widely known as the spin-coating technique. The device is shown in (Figure 2).

Specimen of Spin Coating has been fixed on base of rotation disk via vacuum Spin Coating has been achieved by pouring composite on clean substrate to fully cover it parameter of process have been velocity of Spin 1000 rpm duration 60 sec, Air drying for one day drying in oven At 50°C 1 h.



**Figure 2: Show the system of Spin Coating**

## Electrochemical Measurements

Experiments have been performed in a classical three electrode electrochemical cell. Carbon steel with 1.5 mm thickness and 2.5 cm in diameter has been used as Working Electrode platinum electrode as a counter electrode, silver-silver chloride electrode as a reference electrode. Prior to each experiment, working electrode surface is polished with emery paper. Electrochemical system consists of potentiostat device (Germany, Mlab 2000), corrosion cell (1000ml) volume and the three electrodes with a computer and Mlabsci software used for data acquisition and analysis (Sfimathi, et al.2010). To determine the open circuit potential (OCP) of the specimens, specimens are immersed in the synthesized sea water (3.5% NaCl) at temperatures range (298-328) K to reach the steady state between specimens material and Electrolytic Solution Change in Potential according to current have been determined during (15 min) and time step equal to 60 seconds for each specimens. After reaching the condition of steady state, determined potential is known as corrosion potential or free potential or open circuit potential. Polarization curves are recorded at constant sweep rate of 2 mV/S and scanning range has been from (-200 to +200) mv with respect to open circuit potential. Before each experiment working electrode has been immersed in test cell for 30 minute until reaching steady condition. All tests are carried out at stable temperature (with in  $\pm 1^\circ\text{C}$ ) by controlling cell temperature using a cooling heating Circulating Water Bath.

## Tests of Electrochemical Impedance

The behavior of Corrosion specimen has been monitored using Electrochemical Impedance Spectroscopy (EIS) during immersion in 3.5% NaCl Solution open to air and at room temperature. Three – electrode set-up was used to record corrosion potential of coating. A saturated calomel electrode (SCE) has been used as Reference Electrode. It has been coupled capacitively to a Pt wire to reduce phase shift at higher frequencies. Electrochemical impedance tests have been carried out by using Auto lab type III provided with frequency response analyzer frequency in the range from [1 MHz up to 100 KHz] to collect data with a total number of 40 readings for the whole range. The amplitude of Sinusoidal Voltage signal has been 50 mV. Data have been collected by means of Frequency Response Analyzer software developed by Princeton Applied Research instruments, have been in form of SyQuest plots.

## RESULT AND DISCUSSION:

### Potentiostatic polarization

#### Potentiostatic polarization studies for Carbon Steel 1045 uncoated

The potentiostatic polarization curves for C.S 45 uncoated in 3.5%NaCl solution at temperatures range (298-328) K are shown in (Figure 3). Kinetic parameters of Corrosion such as Corrosion Potential ( $E_{\text{corr}}$ ), Corrosion Current density ( $i_{\text{corr}}$ ), anodic Tafel slope ( $b_a$ ), cathodic Tafel slope ( $b_c$ ) deduced from curves is given in (Table 2). The values of Corrosion Current Density is increase from (113.92)  $\mu\text{A}/\text{cm}^2$  at 298K to (171.29)  $\mu\text{A}/\text{cm}^2$  at 328K. The increase in temperatures lead to increases  $i_{\text{corr}}$ . Values and  $E_{\text{corr}}$ . Goes to more negative potential (active direction).

$$\eta_{a, c} = b_{a, c} \text{Log} \left( \frac{i_{a, c}}{i_0} \right) \dots \dots \dots (1)$$

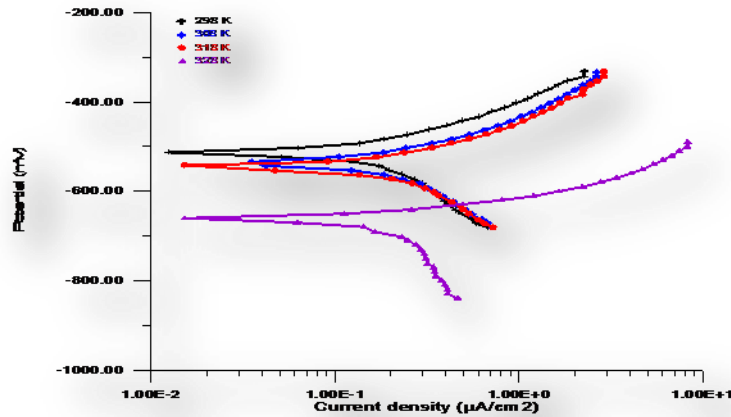

Figure 3: Potentiostatic Polarization Curves of Uncoated C.S 45 In 3.5% NaCl Solution at the temperatures range (298-328) K.

Table 2: Corrosion parameters for C.S 45 alloy uncoated in 3.5% NaCl Solution at a Temperature range (298-328) K.

R/ mpy	Rp/ Ω.cm <sup>2</sup>	P.L/ mm.y <sup>-1</sup>	W.L/ g.m <sup>-2</sup> .d <sup>-1</sup>	ba/ mv.Dec <sup>-1</sup>	-bc/ mv.Dec <sup>-1</sup>	I <sub>corr.</sub> / µA.cm <sup>-2</sup>	-E <sub>corr.</sub> / Mv	-OCP/ mV	Temp/ K
298	500.0	512.7	113.92	164.9	111.4	28.5	1.32	253.41	53
308	521.0	533.4	148.37	183.7	109.9	37.1	1.72	201.24	68
318	527.0	540.3	163.36	197.1	113.0	40.8	1.90	190.91	75
328	646.0	659.7	171.29	310.1	61.1	42.8	1.99	129.39	79

**b- Potentiostatic polarization studies for Carbon Steel 45 coated by Epoxy only & Nan composite using Spin coating**

The applied spin coating deposition of C.S alloy 45 showed different degrees of protection efficiency in different temperatures. The protection efficiency (PE) was obtained from equation (2) at temperature range (298-328) K, as show in (Table 3).

$$\%PE = \frac{(I_{corr})_{uncoated} - (I_{corr})_{coated}}{(I_{corr})_{uncoated}} * 100 \dots\dots\dots (2)$$

Table 3: Corrosion parameters for C.S 45 alloys coated with Epoxy only by spin coating at temperature range (298-328) K in 3.5% NaCl solution.

Temp/ K	-OCP/ mV	-E <sub>corr.</sub> / mV	I <sub>corr.</sub> / µAcm <sup>-2</sup>	bc/ mVdec <sup>-1</sup>	ba/ mVdec <sup>-1</sup>	W.L/ gm <sup>-2</sup> .d <sup>-1</sup>	P.L/ mm.y <sup>-1</sup>	Rp/ Ω.cm <sup>2</sup>	R/ mpy	PE%
298	497.0	509.9	49.75	142.0	128.0	12.4	0.577	587.55	23	56.33
308	549.0	551.1	54.31	125.2	110.5	13.6	0.63	469.28	25	63.39
318	552.0	565.8	65.43	124.9	107.1	16.4	0.759	382.64	30	59.94
328	557.0	569.7	71.10	120.9	120.1	17.8	0.825	367.95	33	58.49

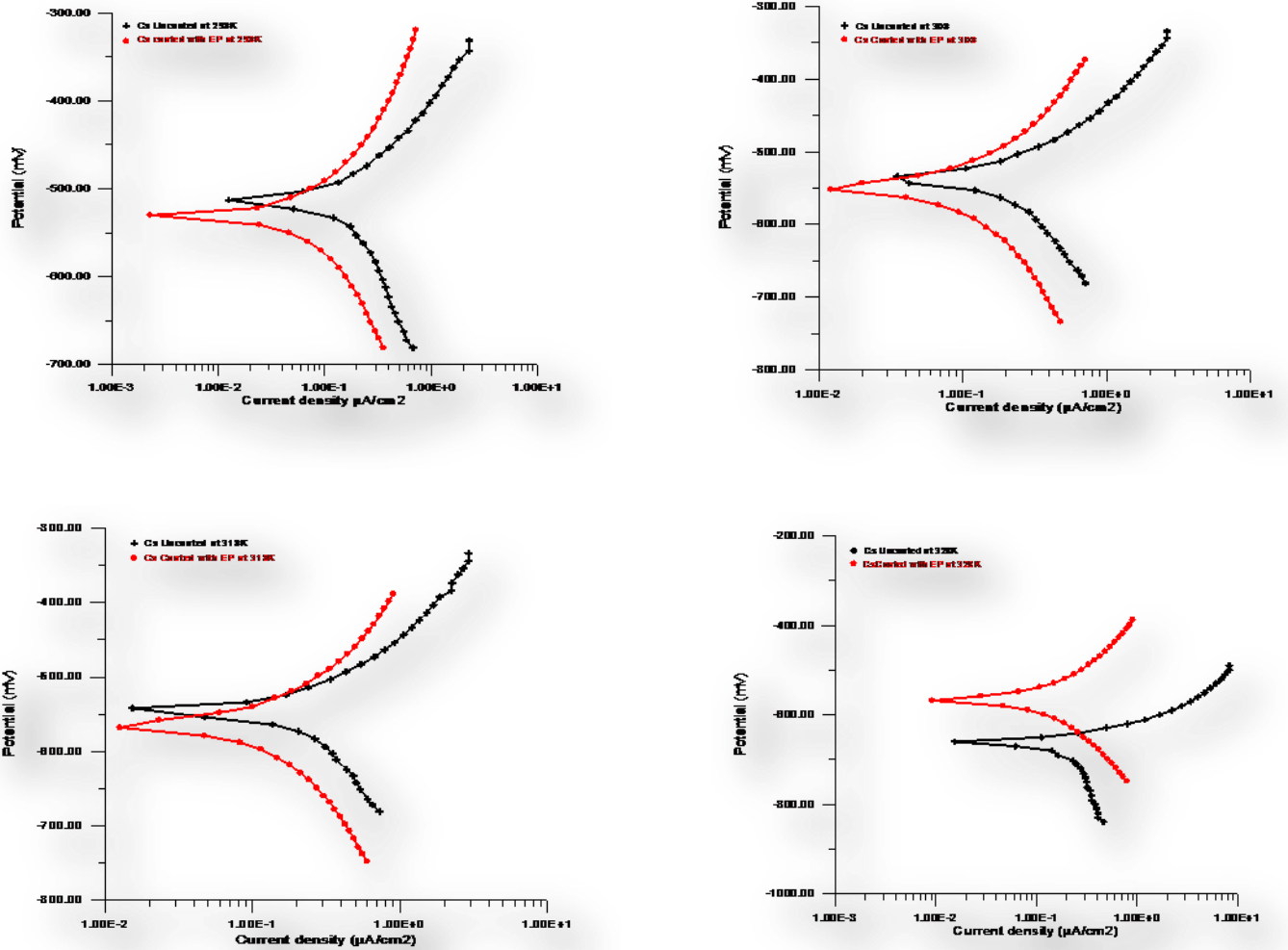

Figure4: The polarization curves for the corrosion of C.S 45 Coated with Epoxy only by spin coating in a different temperatures as compared with the polarization curves for Uncoated C.S 45

Table 4: Corrosion parameters for C.S 45 alloys coated with 9%Nanocomposite by spin coating at temperature range (298-328) K in 3.5% NaCl solution.

Temp/ K	-OCP/ mV	-E <sub>corr.</sub> / mV	I <sub>corr.</sub> / Acm <sup>-2</sup> µ	bc/ mV dec <sup>-1</sup>	ba/ mV dec <sup>-1</sup>	W.L/ g. m <sup>-2</sup> .d <sup>-1</sup>	P.L/ mmy <sup>-1</sup>	Rp/ Ω.cm <sup>2</sup>	R/ mpy	PE%
298	390.0	401.3	1.39	194.3	109.0	0.348	0.0162	21813.14	0.6	98.78
308	435.0	447.9	2.59	115.2	79.9	0.647	0.030	7909.49	1.2	98.25
318	461.0	474.9	3.32	173.5	105.5	0.83	0.0385	8580.56	1.5	97.96
328	463.0	476.6	4.11	217.0	113.6	1.03	0.477	7877.00	1.9	97.60

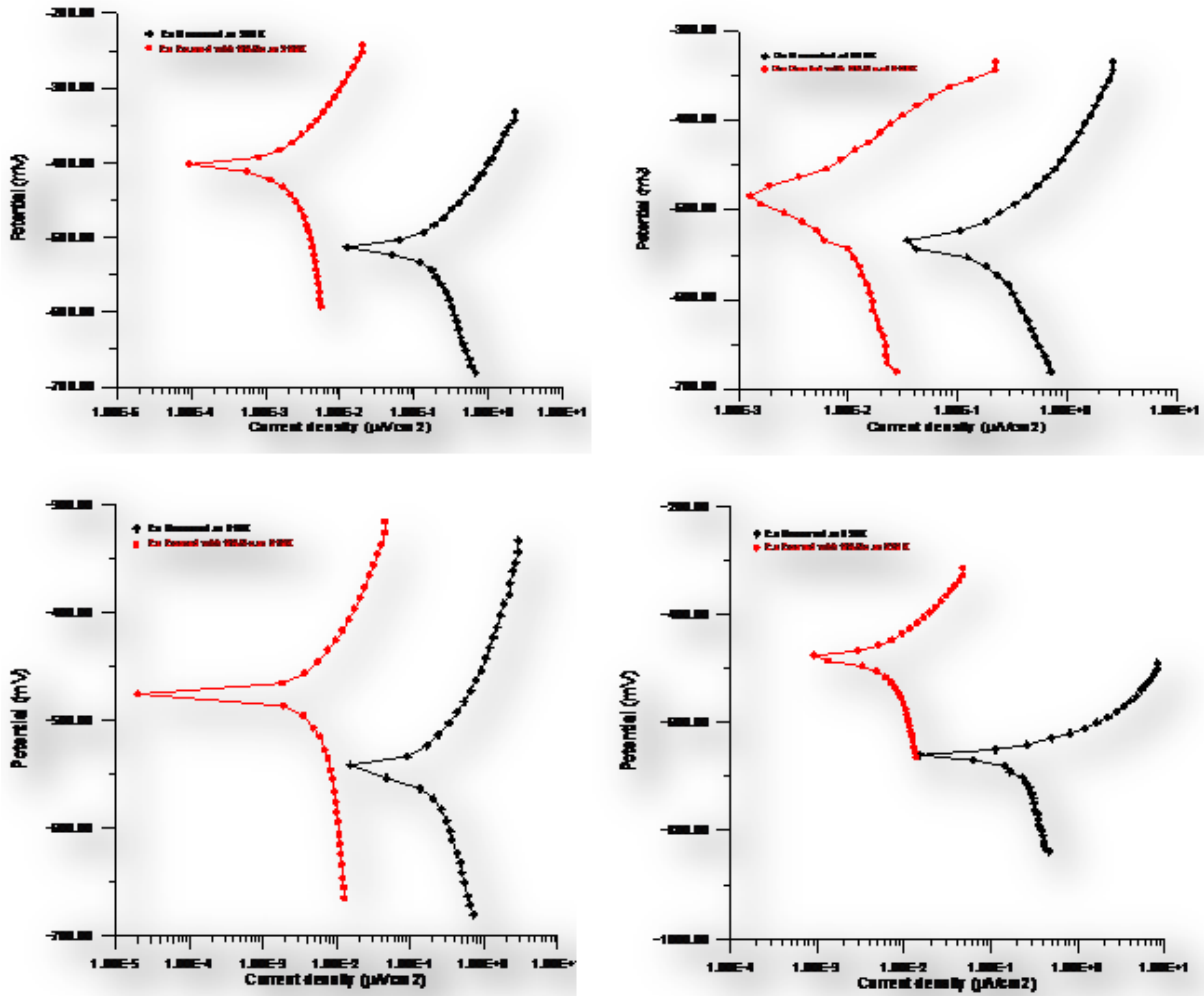

Figure 5: The polarization curves for the corrosion of C.S 45 Coated with 9% Nan composite by spin coating in a different temperatures as compared with the polarization curves for Uncoated C.S 45.

The corrosion potentials were shifted to more active with temperature increasing. Corrosion potentials corrosion current densities are determined via extrapolating the Cathodic and Anodic Tafel regions, the intersect opposite the corrosion current and corrosion potential. (Figure 4) show the polarization curve of C.S 45 Coated with different concentration of Nan composite at 298K. In compared with the polarization curves for uncoated C.S 45, the corrosion potential for coated C.S 45 to more noble direction.

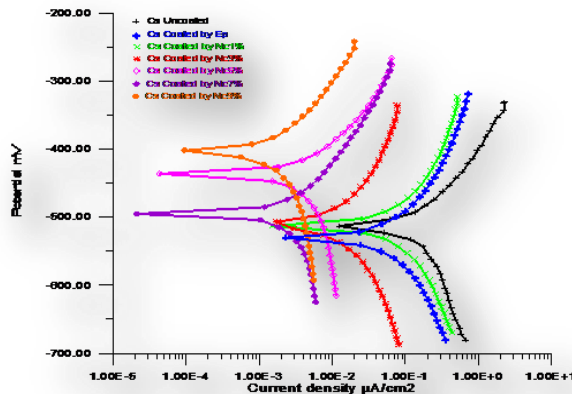

Figure 6: Polarization curves for C.S 45 coated with Nan composite at different concentrations as compared with the polarization curves of uncoated C.S 45 at 298K.



**Table 5: Corrosion parameter for coated C.S 45 with Nan composite at different concentrations In 3.5%NaCl at 298K.**

State	-OCP	E <sub>corr.</sub> / -mv	i <sub>corr.</sub> / μA.cm <sup>-2</sup>	bc/ mV. dec <sup>-1</sup>	ba/ mV. dec <sup>-1</sup>	W.L/ g.m <sup>-2</sup> . d <sup>-1</sup>	P.L/ mm. y <sup>-1</sup>	Rp/ Ω.cm <sup>2</sup>	PE%	R/ mpy
C.S 45 Uncoated	500.0	512.7	113.92	164.9	111.4	28.5	1.32	253.41	-----	53
C.S 45 Coated by EP	517.0	529.9	49.75	142.0	128.0	12.4	0.577	587.55	56.33	23
C.S 45 Coated by 1% Nan composite	500.0	512.6	44.11	109.4	106.9	11	0.512	532.24	61.28	20
C.S 45 Coated by 3% Nan composite	496.0	507.2	8.45	124.5	111.8	2.11	0.0981	3026.89	92.58	4
C.S 45 Coated by 5% Nan composite	422.0	435.6	2.97	189.8	88.5	0.743	0.0345	8824.21	97.39	1
C.S 45 Coated by 7% Nan composite	481.0	494.4	1.94	191.2	101.4	0.485	0.0225	14830.50	98.30	0.9
C.S 45 Coated by 9% Nan composite	390.0	401.3	1.39	194.3	109.0	0.348	0.0162	21813.14	98.78	0.6

There are two important trends that are evident first of all, Corrosion Potential is shifted toward more passive value in Coated with Nan composite by using spin coating, Second Corrosion Current densities have been significant reduced with Coated via Nanocomposite by spin coating, Where Protection Efficiencies (PE) ranged between (61.28%) at 298K to (98.78%) at 328K for carbon steel (1045), (Table 5) show the corrosion kinetic parameter deduced from this curve.

**Kinetic and Thermodynamic Studies:**

Thermodynamic parameters play an important protection mechanism. From Eq. (3) the values of the slopes of these straight lines permit the calculation of the similar Arrhenius activation energy (Ea).

$$\text{Log} i_{\text{corr.}} = \left( \frac{-E_a}{2.303RT} \right) + \text{Log A} \dots\dots\dots (3)$$

Where(R) is gas constant (R = 8.314JK<sup>-1</sup>mol<sup>-1</sup>), and determine the Arrhenius factor from intercept. Moreover, transition state Eq. (4) was used [8]

$$\text{Log} \left( \frac{i_{\text{corr.}}}{T} \right) = \text{Log} \left( \frac{R}{Nh} \right) + \frac{\Delta S^*}{2.303R} - \frac{\Delta H^*}{2.303RT} \dots\dots\dots (4)$$

Where i<sub>corr.</sub> Is corrosion current density, T is temperature in K, h is the planks constant (6.626 × 10<sup>-34</sup> J.S), N is the Avogadro’s number (6.023 × 10<sup>23</sup> mol<sup>-1</sup>), ΔH\* is the enthalpy of activation and ΔS\* is the entropy of activation, Straight line have been obtained from plots of i<sub>corr.</sub> / T Versus. 1/ T, with the slope of (-ΔH\* / 2.303R) and an intercept of [log(R/ Nh) + ΔS\* / 2.303 R] from which the data of ΔH\* and ΔS\*, respectively have been calculated as shown in (Figures 7-9)for C.S 45 Aiioy uncoated and coated, By using the estimated values of ΔH\* and ΔS\*, it was possible to calculate the values of the change in Gibbs Free Energy ΔG\* of activation for Corrosion process from the relation:

$$\Delta G^* = \Delta H^* - T \Delta S^* \dots\dots\dots (5)$$

ΔH\*, ΔS\*, Ea and A values for Cs45 alloy before and after coating were illustrated in (Tables 6-8).



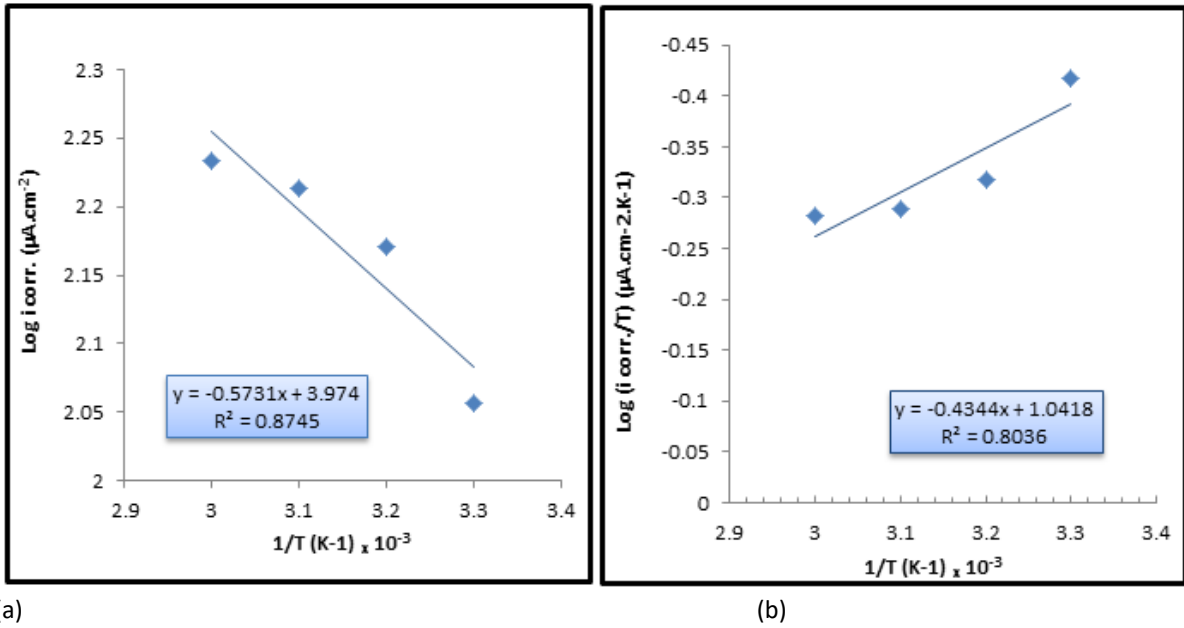

Figure 7: (a) Arrhenius plot,  $\log i_{corr.}$  Versus  $1/T$ - (b)  $\log (i_{corr.} / T)$  against  $(1/T)$  plot of Uncoated C.S 45 in 3.5% NaCl solution

Table 6: Transition state thermodynamic parameter at different temperatures for the corrosion of uncoated C.S 45 alloy in 3.5% NaCl Solution

Temp/ K	$1/T/ K^{-1}$	$i_{corr.}/ \mu A.cm^{-2}$	$\log i_{corr.}$	$\log (i_{corr.}/T)$	$\Delta G^*/ KJmol^{-1}$	$\Delta H^*/ KJmol^{-1}$	$\Delta S^*/ Jmol^{-1}$	$E_a/ KJmol^{-1}$	A/ Molecules. $cm^{-2}S^{-1}$
298	0.0033	113.92	2.057	-0.418	61.23	8.32	-177.54	10.97	5.67E+27
308	0.0032	148.37	2.171	-0.317	63.00				
318	0.0031	163.36	2.213	-0.289	64.78				
328	0.0030	171.29	2.234	-0.282	66.55				

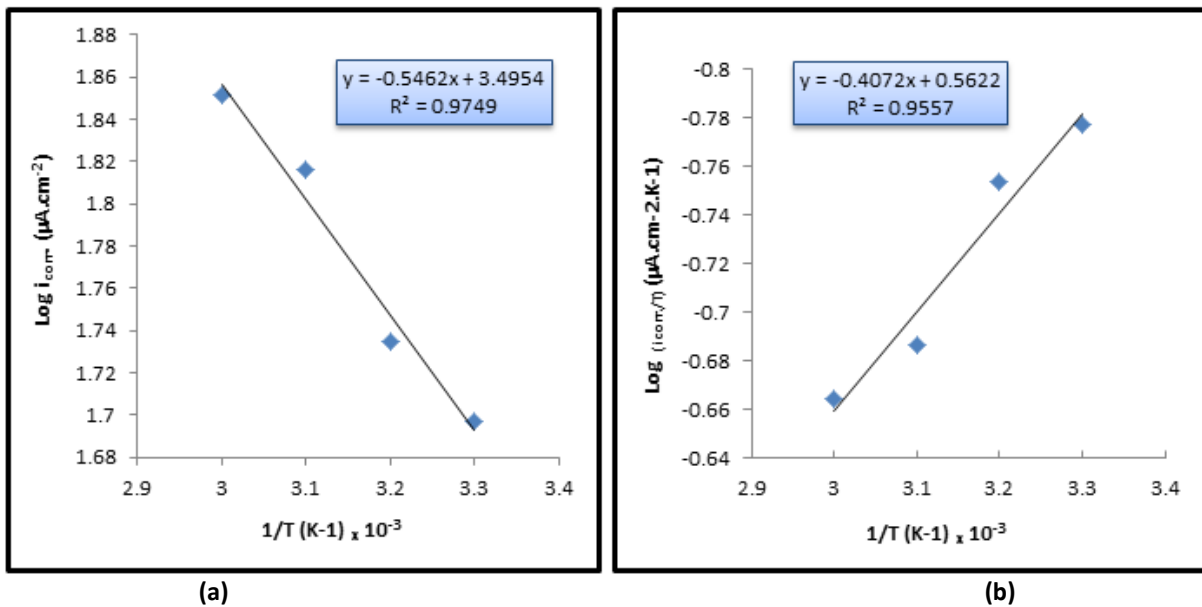
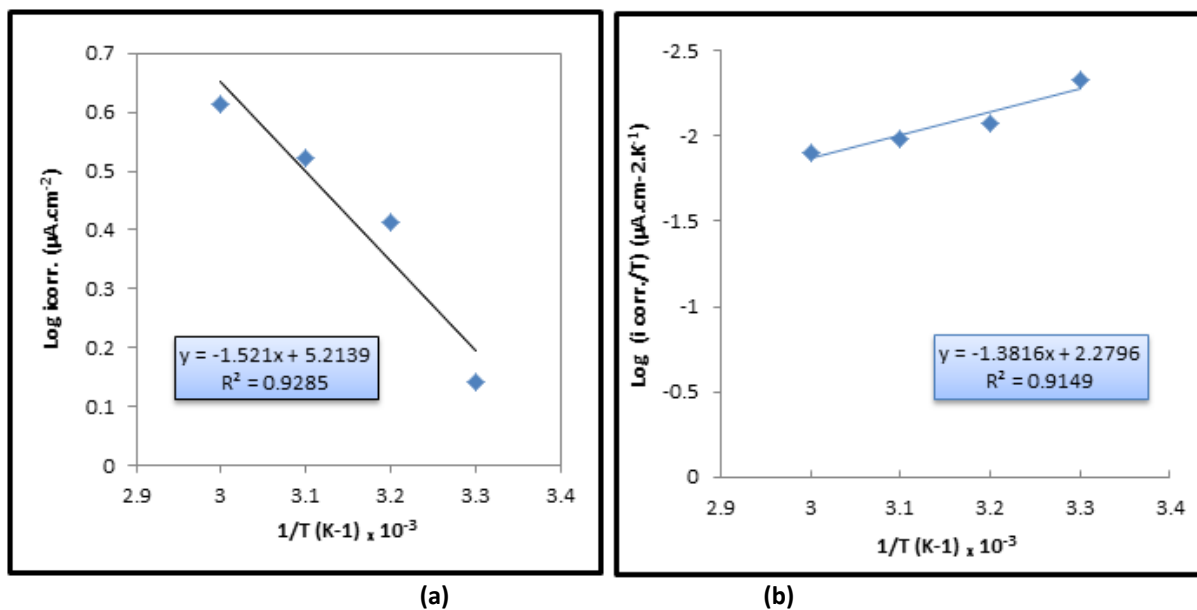

Figure 8: (a) Arrhenius plot,  $\log i_{corr.}$  Versus  $1/T$ - (b)  $\log (i_{corr.} / T)$  against  $(1/T)$  plot of C.S 45 Alloy Coated with Epoxy only by Spin coating in 3.5% NaCl solution

**Table 7: thermodynamic quantities for the corrosion transition state at a different temperatures for the C.S 45 alloy coated with Epoxy only by Spin coating Techniques in 3.5% NaCl Solution**

Temp/ K	1/T/ K <sup>-1</sup>	<i>i</i> <sub>corr.</sub> / μA.cm <sup>-2</sup>	Log <i>i</i> <sub>corr.</sub>	Log ( <i>i</i> <sub>corr.</sub> /T)	Δ <i>G</i> <sup>*</sup> / KJmol <sup>-1</sup>	Δ <i>H</i> <sup>*</sup> / KJmol <sup>-1</sup>	Δ <i>S</i> <sup>*</sup> / Jmol <sup>-1</sup>	E <sub>a</sub> / KJmol <sup>-1</sup>	A/ Molecules. cm <sup>-2</sup> S <sup>-1</sup>
298	0.0033	49.75	1.697	-0.777	58.07	7.79	-186.72	10.49	1.88E+27
308	0.0032	54.31	1.735	-0.754	59.76				
318	0.0031	65.43	1.816	-0.687	61.44				
328	0.0030	71.10	1.852	-0.664	63.13				



**Figure 9: (a) Arrhenius plot, log *i*<sub>corr.</sub> Versus 1/T- (b) Log (*i*<sub>corr.</sub> / T) against (1 / T) plot of C.S 45 Alloy Coated with 9%Nanocomposite by Spin coating in 3.5% NaCl Solution.**

**Table 8: Thermodynamic parameter for the corrosion transition state at different temperatures for the C.S 45 alloy coated with 9%Nanocomposite by Spin coating Techniques in 3.5% NaCl Solution.**

Temp/ K	1/T/ K <sup>-1</sup>	<i>i</i> <sub>corr.</sub> / μA.cm <sup>-2</sup>	Log <i>i</i> <sub>corr.</sub>	Log ( <i>i</i> <sub>corr.</sub> /T)	Δ <i>G</i> <sup>*</sup> / KJmol <sup>-1</sup>	Δ <i>H</i> <sup>*</sup> / KJmol <sup>-1</sup>	Δ <i>S</i> <sup>*</sup> / Jmol <sup>-1</sup>	E <sub>a</sub> / KJmol <sup>-1</sup>	A/ Molecules. cm <sup>-2</sup> S <sup>-1</sup>
298	0.0033	1.39	0.143	-2.331	72.29	26.45	-153.84	29.12	9.86E+28
308	0.0032	2.59	0.413	-2.075	73.83				
318	0.0031	3.32	0.521	-1.981	75.37				
328	0.0030	4.11	0.614	-1.902	76.91				

**Electrochemical Impedance Tests Cs<sub>45</sub> uncoated:**

We see from EIS measurement that the behavior of Cs<sub>45</sub> is ideal ads shown in (Figures 10 & 11), where the equivalent circuit refers to Randle circuit.

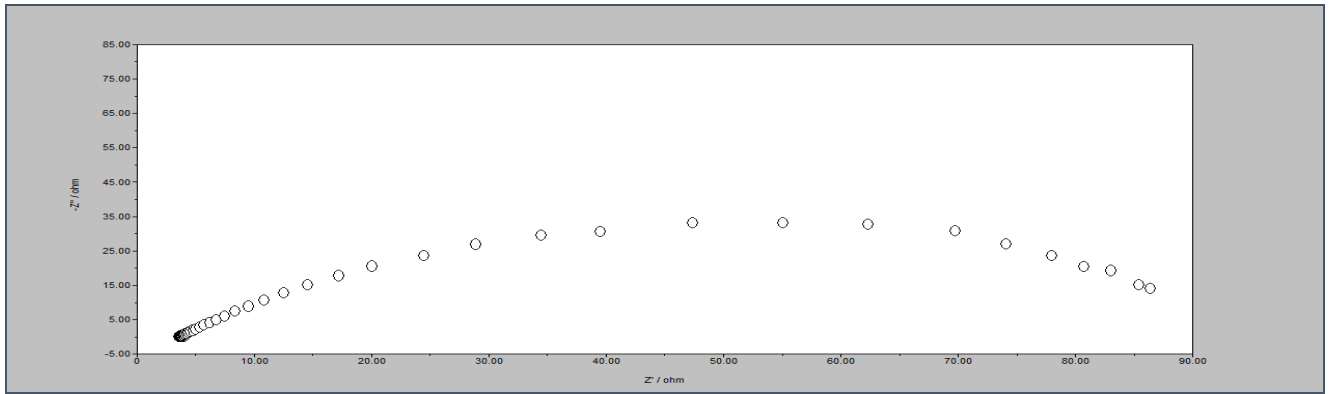

Figure 10: SyQuest impedance diagram for C.S45 Uncoated In 3.5% NaCl Solution At 298K.

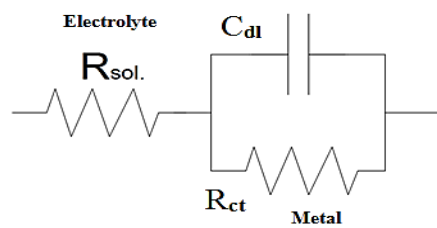

Figure 11: Equivalent Circuit diagram, Model R (CR) for C.S 45 Uncoated in 3.5% NaCl Solution at 298K.

**C.S 45 coated with Epoxy:**

From (Figures 12&13), which represent the Nyquist plot and equivalent circuit, we see there are porous layers that appear obviously in equivalent circuit modeling. The SEM ensured the apper of porous layer which increase the resistance and decreased the corrosion.

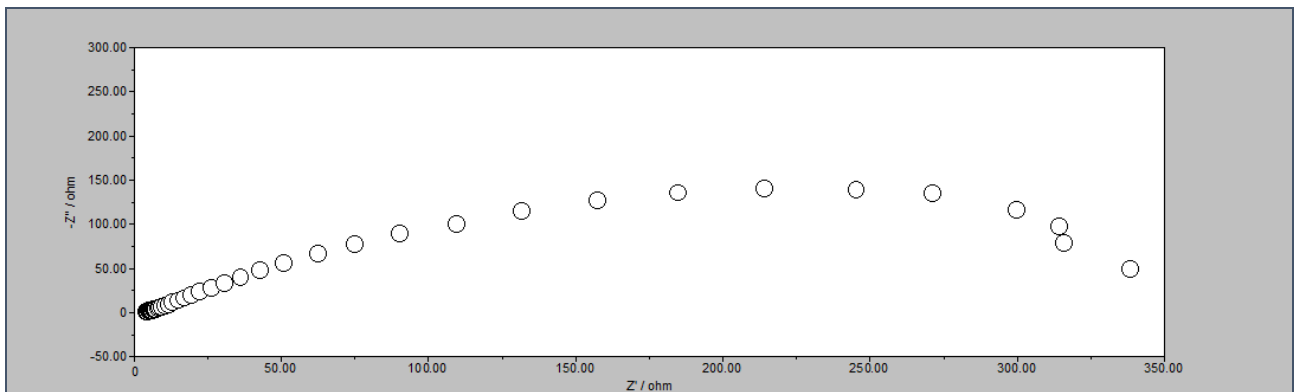

Figure 12: SyQuest impedance diagram for C.S 45 Coated with Epoxy by Spin coating in 3.5% NaCl Solution At 298K.

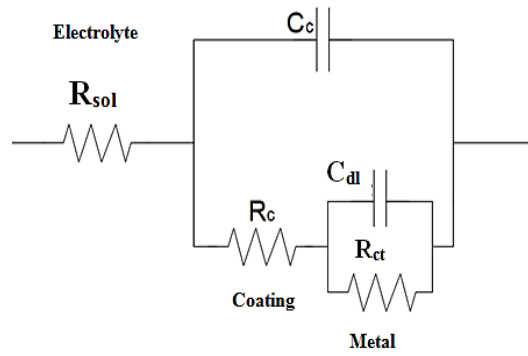

Figure 13: Equivalent Circuit diagram, Model R (C(R (CR))) for C.S45 Coated with Epoxy by Spin coating in 3.5% NaCl Solution at 298K.

Cs45 coated with 9% Nan composite

We see obviously there is change in behavior for SyQuest or equivalent circuit, i.e. the Nano material affects the corrosion as show in (Figures 14&15) below:

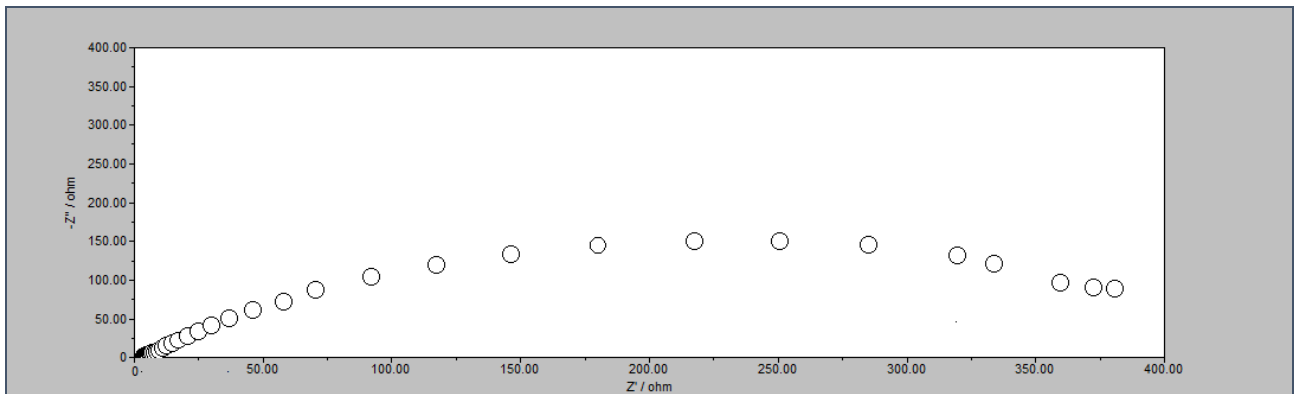

Figure 14: SyQuest impedance diagram for C.S 45 Coated with 9% Nanocomposite by Spin coating in 3.5% NaCl Solution At 298K.

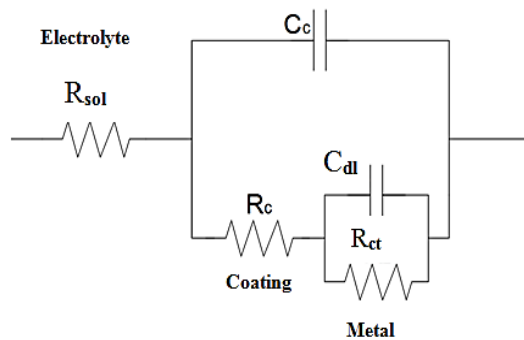

Figure 15: Equivalent Circuit diagram, Model: R (C (R (CR))) for C.S 45 Coated with 9% Nanocomposite by Spin coating in 3.5% NaCl Solution at 298K.

Table9: Electrochemical Parameter of Equivalent circuits obtained from best fit to impedance data for C.S 45 Uncoated and Coated in 3.5% NaCl solution at 298K.

Stat	RS (Ω)	RC (Ω)	RCT (Ω)	Ttotal (Ω)	CC (F)	Cdl (F)	n1	n2
C.S Uncoated	5.1	-----	98	103.1	-----	3.51E-4	0.8047	-----

Coated With Epoxy	4.9	2.7E+2	1.01E+2	375.9	4.1E-4	1.3E-3	0.8432	0.8764
Coated With 9% Nan composite	4.95	2.8E+2	1.1E+2	394.95	4.2E-4	1.01E-3	0.8416	0.9012

EIS spectrum in high frequency region is attributed due to coating behavior and low frequency region corresponds to corrosion reaction [9].  $R_{sol}$  is constant at (4.9-5.1)ohm in 3.5% NaCl solution. The capacitance component is thought to be Double layer capacitance of the corrosion ( $C_{dl}$ ) at the C.S 45 surface. Low resistances in the spectrum are thought to be coating resistance in the high-frequency region and a charge transfer resistance ( $R_{ct}$ ) in low-frequency region corresponds to corrosion reaction. The Nyquist plots show that  $Z_{low}$  for C.S 45 Uncoated is very much lower in (Figure 10), than the C.S 45 Coated with Epoxy and Nan composite (Figures 12 & 14) respectively. These results show that C.S 45 Coated with Epoxy and Nan composite can keep high corrosion resistance even though C.S 45 Uncoated has heavy Corrosion during the test time. EIS data in present work might be explained using Equivalent Electrical Circuit model displayed in (Figures 11, 13&15) where  $R_{sol}$  denotes the solution resistance,  $R_{ct}$  indicates the charge transfer resistance corresponding to the corrosion reaction,  $C_c$  is capacitance of coating, and  $C_{dl}$  is Double layer Capacitance of the Corrosion reaction.

**Scanning Electron Microscopy (SEM):**

SEM is a technique which uses electromagnetic lenses and an electronic beam to illuminate samples under vacuum [10, 11]. Scanning Electron Microscope scans a focused electron beam over a surface of a sample to create an image. Electron interaction with atoms of surface, producing various signals can be used to obtain acquaintance about surface topography and composition.

SEM image carbon steel (1045) surface with Nan composite and Epoxy coatings in 3.5% NaCl indicated that the composite phase between the C.S surface and the film coating was established, and the film coating are homogeneous, the (SEM) image in (Figures 16 & 17) shows the particles on the surface and uniformly distributed throughout the surface and the distributed and the coverage of Magnetite Nan composite are more uniform than the distributed of Epoxy.

The Scale bar for this image is (1, 2, 20)  $\mu$ m and (200,300) nm and the energy of the acceleration beam employed was 25Kv.

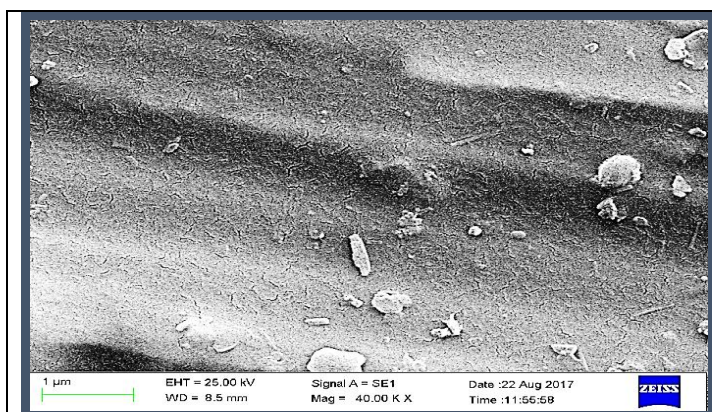

(a)

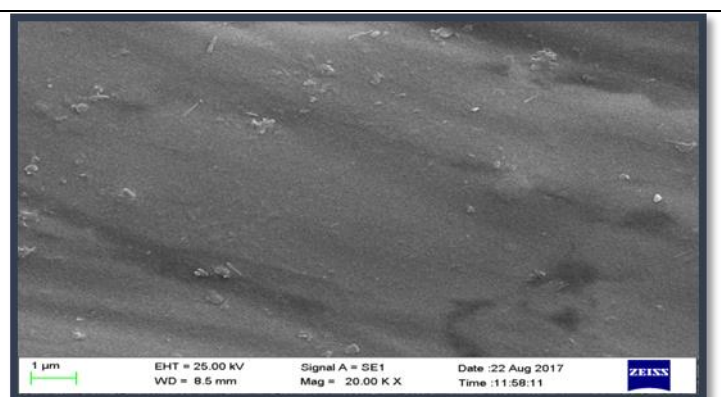

(b)



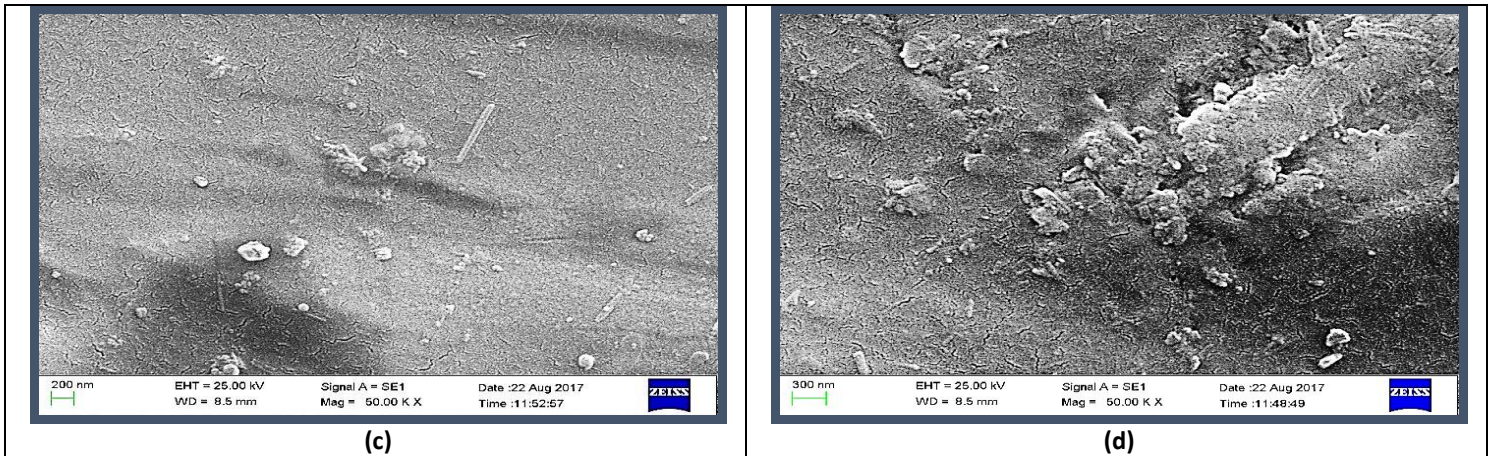

Figure 16: SEM image of Epoxy coating (a/1 $\mu$ m), (b/1 $\mu$ m), (c/200nm), (d/300nm).

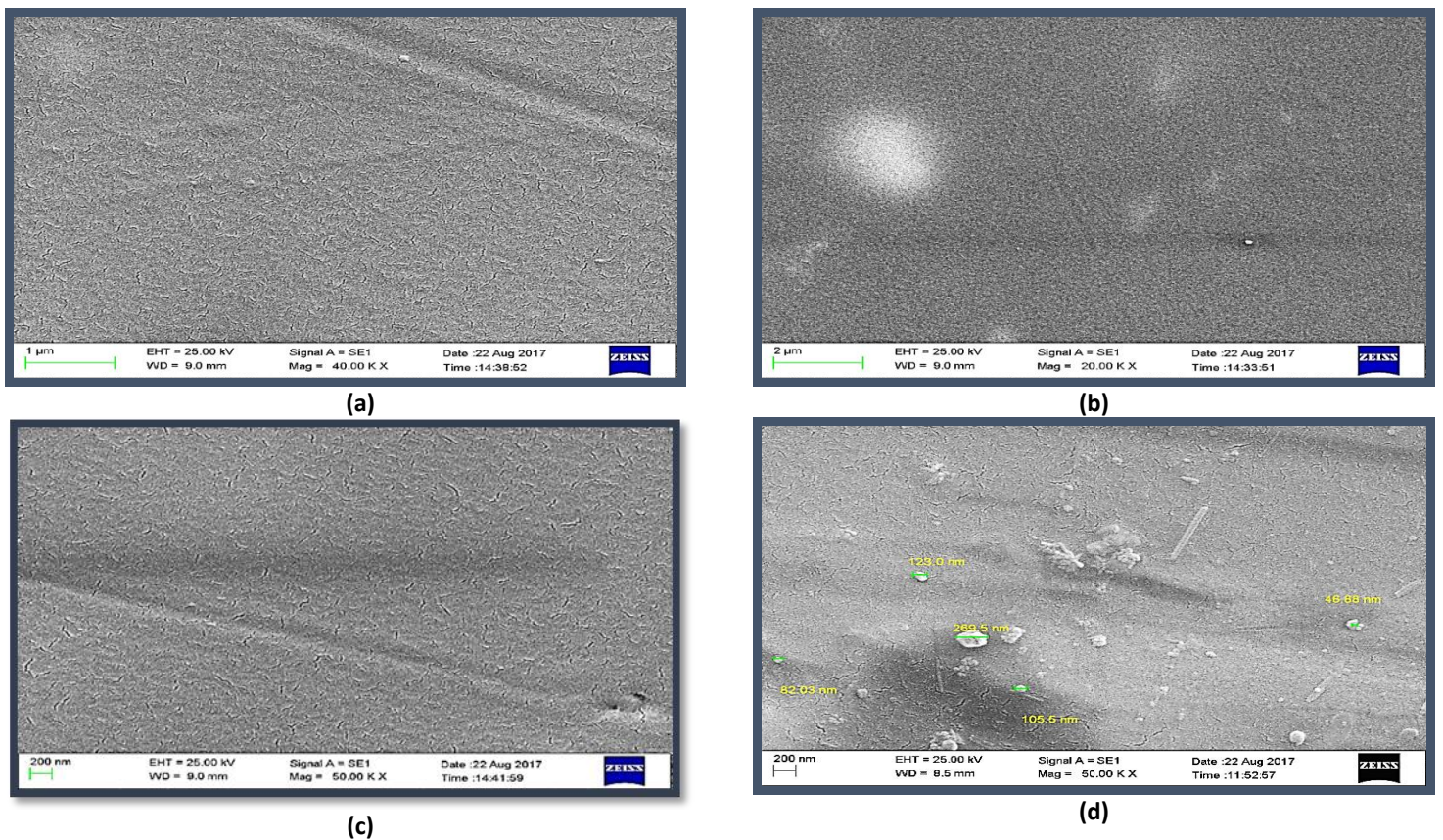

Figure 17: show the SEM image of the deposited of Magnetite and Epoxy as Nan composite, it shows compact highly ordered homogeneous with particle size around (46.88) nm over a large area of the surfaces.

### CONCLUSIONS

The Protection efficiency of Carbon Steel (1045) corrosion in 3.5% NaCl by Nan composite and Epoxy has been investigated using electrochemical measurement. The following conclusions were drawn from this study: Nan composite and Epoxy film acted as excellent protection for corrosion of C.S 45alloy in 3.5%NaCl Solution, The coated Carbon Steel (1045) with Nan composite by Spin Coating reduced corrosion rate compared to coated sample with Epoxy only while that coating C.S with Epoxy only reduced corrosion rate compared to uncoated sample. Corrosion protection efficiencies of Nan composite increased with their concentration and their values obtained from Polarization method and electrochemical impedance, and the

data obtained are in good agreement. Spin Coating Deposition Technique was successfully applied to coat C.S 45 alloy. In Conclusion, EIS data will be very useful In Predicting the corrosion resistance coated.

#### **ACKNOWLEDGEMENT**

The authors would like to thank Mr. Aqeel Faleeh Hasan for his constant encouragement and assistance in explaining the result for EIS which has been an essential component of this research.

#### **REFERENCES**

- [1] Rasha, A.J; Ahlam, M. F. and Abdul kareem, M.A. J.Baghdad for Sci.2014. 11 (1):116-122.
- [2] Ibtihal, A.M.; Malia M. F. and Noora T.M. AJASE 2015. 4(3):157-166.
- [3] Atta, A.M.; EL-Mahdy, G.A.; AL-Lohedan; H.A. and AL-Hussain, S.A. J Nanomater Biostruct. 2014. 9(2):627-639.
- [4] Indira, K. and Nishimura, T. Int.J.Electrochem.Sci. 2016. 11:419-431.
- [5] Rakesh, N.P.; Brihari, V. Sh. and Prakash A. M. JMMCE. 2012. 11:1012-1019.
- [6] Shi, X.; Nguyen, T.A.; Suo, Z.; Liu, Y. and Avci, R. Surface & Coating Technology. 2009. 204:237-245.
- [7] Nadia, H.; Hacence,C. ; Gildas, G. and Kamel, B. ACES. 2011., 1(2):51-60.
- [8] Rehab, M.K; Mustafa, M. K, Suaad, M. A and AbdulKareem, M.A. IJAIEM. 2016. 5(8):2319-4847.
- [9] Madhankumar, A.; Nagarajan, S.; Rajendran, N. and Nishimura; T. J. Solid State. Electrochemist. 2011., DOI 10.1007/s10008-011-1623-1.
- [10] Tribak, Z.; Kharbach, Y.; Haoudi, A.; Skalli, M.K.; Kandri, R.Y.; Azzouzi, M.El.; Aouniti, A.; Hammouti, B. and Senhaji, O. J. Mater. Environ. Sci. 2016., 7(6): 2006-2020.
- [11] Schatten, H. 2013. Scanning Electron Microscopy for the Life Sciences. Cambridge University Press. e-Book.