

Research Journal of Pharmaceutical, Biological and Chemical Sciences

Design of an incinerator to treat combined biomedical wastes generated from four major hospitals in Chandigarh and Shimla City, India.

Rajiv Ganguly^{1*}, Prachi Vasistha², and Ashok Kumar Gupta¹.

¹Department of Civil Engineering, Jaypee University of Information Technology, Wanknaghat, District Solan, Himachal Pradesh - 173234, India.

²Department of Civil Engineering, Chandigarh University, Mohali, Punjab - 140413, India

ABSTRACT

It is of prime importance to provide adequate healthcare facilities for a developing country. In this context, the India Government has been successful in implementing these objectives. However, with the increase in healthcare provisions has also lead to massive increase in generation of biomedical wastes. Inefficient handling of Health Care Wastes (HCW) in a hospital environment poses a severe threat to workers, patients, waste handlers and the general human community due to possibility of transmission of pathogens. Hence, a sound biomedical waste management practice is needed to avoid any potential issues. In general, a sound waste management technique involves appropriate planning including collection, segregation, storage, treatment and disposal procedures and adequate training of the workers involved in the process. In general, incineration is one of the most widely used techniques for disposal of biomedical wastes. The process involves burning of the waste at very high elevated temperatures (1500°C) under controlled operating conditions in a chamber known as incinerator. The end products generated are carbon dioxide and water with ash as residual material. The paper presents in an in-depth analysis of design aspects of the incineration chamber.

Keywords: Biomedical Waste, Hazardous substances, Incineration process, Heat generation, Chandigarh, Shimla.

**Corresponding author*

Email: rajiv.ganguly@juit.ac.in

INTRODUCTION

Proper management techniques are very important for biomedical waste management as any deficiencies in the system can cause severe problems. Proper management of biomedical waste includes proper procedures for collection, segregation, storage, transportation and disposal of solid waste [3]. Majority of biomedical wastes generated in hospitals are organic in nature and primarily consists of carbon, hydrogen, halogens, nitrogen, heavy metals and other certain chemicals (traces). Due to the nature of the wastes generated in a healthcare facility, incineration is considered to be one of the best methods for detoxification and safe disposal of biomedical waste [6].

Incineration is generally defined as the destruction of wastes at relatively high temperatures of 1200°C to 1600°C under controlled conditions for destruction and detoxification of biomedical wastes. The high temperature is required to be maintained in the incinerator chamber to ensure complete combustion of the toxins and pathogens, elimination of odors without damaging any internal components of the system [4]. The final end products after incineration process are primarily CO₂, water and residual ash [4]. The CO₂ generated from the incineration process will be have considerably less effect as a greenhouse gas in comparison to CH₄ that will be generated due to anaerobic process if the waste was dumped in open landfill (CH₄ has 1.38 times more potent as greenhouse gas than CO₂). The equipment in which the process is done is called an Incinerator. In practice, there are primarily three types of incinerators available including Multiple Chamber (retort and in-line), Controlled Air and Rotary Kiln type of incinerators [12].

Multiple Chamber Incinerator is one of the most widely used incinerators for disposal of biomedical waste. In this incinerator, the combustion of waste is a two-stage process. The first stage involves application of the biomedical waste in the primary chamber wherein it is operated on a limited supply of air (less than the stoichiometric requirement) for the combustion process whereas the second stag involves addition of excess air to oxidize the volatile gases generated from the first stage reactions. It is important to note that since air rates in the primary chamber is low, entrained particulates in the volatile gases generated and leaving the primary chamber is low due to which gas cleaning devices are absent for controlled air incinerators. Figure 1 shows the line diagram to explain the incineration process inside a Multiple Chamber Incinerator [5].

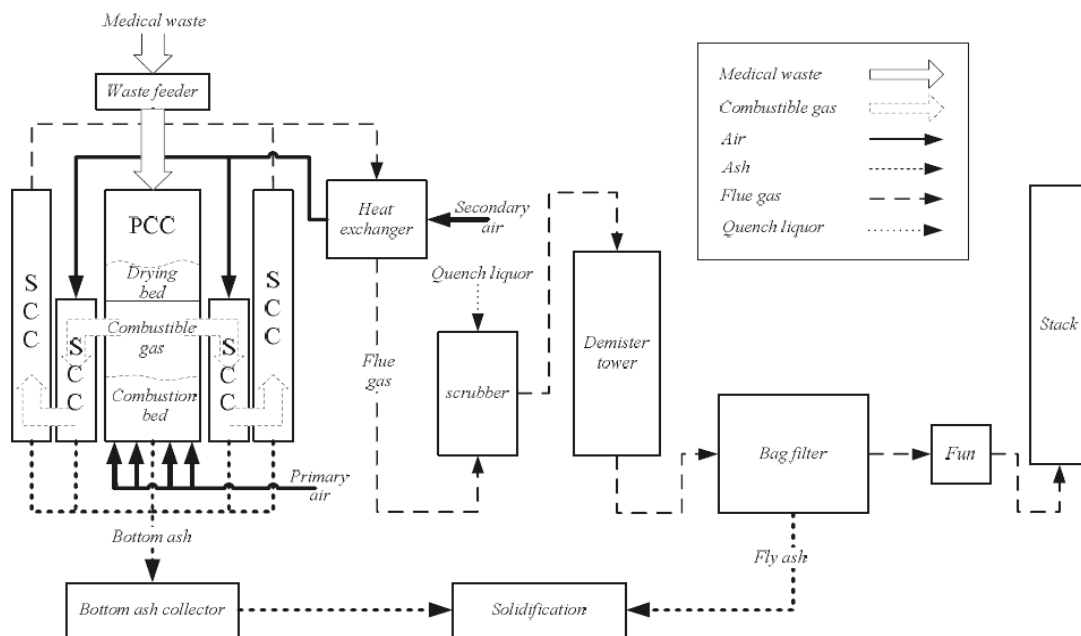

Figure 1: Schematic diagram of incineration system. [12]

Incineration process is an effective means of reducing the biomedical waste volume particularly for high population density areas and consequently with less availability of land area for landfill sites. It is a clean and efficient waste disposal technology as it reduces the amount of residue to be dumped in the landfill site by about 30-35% [8]. Proper disposal of residual ash will also reduce risk of groundwater contamination.

However, there remain environmental and technical issues in the incineration primarily due to emissions and nature of residual solids in ash after burning process [8].

Site Location

Shimla is located in the south-western districts of Himachal Pradesh and lies between the UTM coordinates of (699211.48, 3499122.47) located in the UTM zone of 43R at a height of 2000 m above MSL in ‘middle Himalayas’. As per the latest population census carried out in India in the year 2011, the population of Shimla district is 8, 14,010 with a population density of 159 inhabitants per km² covering an area of 5131 km². Chandigarh lies within the UTM coordinates of (670358.11, 3401399.32) in the zone 43R covering an area of 114 Km² and has a population of 1.05 million as per 2011 census with a decadal growth rate of 17%.

MATERIAL AND METHODS

The following sub-sections explain the methodology carried out for complete design of the incinerator.

Quantification of Waste

The total quantity of waste generated in Shimla and Chandigarh (from four major hospitals) on a monthly and daily basis was quantified to obtain a sample size of waste to be used for designing purpose [3]. This is much greater than earlier reported literature [7]. This has been in shown in Table 1. It is observed from Table 1 that the total waste generated per day is 449.36 kg/day and hence the design waste is assumed to be 500 kg/day

Table 1: Waste generation from four major hospitals in Shimla and Chandigarh city used for incinerator design

S.No.	Name of Health Establishment	Quantity of Waste generated/ month	Quantity of Waste generated/ day
1.	IGMC Hospital, Shimla	3,012 kg/month	100.4 kg/day
2.	INDUS Hospital, Shimla	97.8 kg/month	3.26 kg/day
3.	MAX Hospital, Mohali	6,498 kg/month	216.3 kg/day
4.	IVY Hospital, Mohali	3,882 kg/month	129.4 kg/day

Design of an Incinerator

The following steps were used to design the incinerator. Each step of the design procedure has been discussed in great details including the assumptions involved in the design process.

Design of Primary Chamber

For designing of Primary chamber of Multiple Chamber Incinerator under controlled air conditions initially volume of primary chamber is to be determined so as 500 kg of waste is dumped and the volume of heap is considered [1].

Volume of heap (for 500 kg of waste) = 8m³
 Assuming suitable depth of 3 m we can find the area of chamber as
 Area = Volume/Depth
 = 8/3
 = 2.66 m²
 Assume the ratio of length and breadth as 1.75:1
 Therefore L/B = 1.75/1
 L = 1.75B
 Dimensions of Primary Chamber = L*B*H

$$\begin{aligned} \text{Area} &= L*B \\ 2.66 &= 1.75 B*B \\ 2.66 &= 1.75 B^2 \\ B &= 1.23 \text{ m} \\ L &= 2.16 \text{ m} \\ H &= 3 \text{ m} \end{aligned}$$

Hence, the dimensions of the primary chamber are 2.16 m x 1.23 m x 3 m

Heat and Material Balance Sample Calculations

The design of an incinerator is highly influenced by the heat and material balance which evaluates the input and output contents of the incinerator. This determines the auxiliary fuel requirements and combustion air requirements or to determine the limitations for Incinerator when charged with known quantity of waste.

The general assumption is that an incinerator is designed for incineration of 30% of red bags and 70 % of yellow bags (PVC contented 5%) of the biomedical waste [9]. In general, the waste input rate is 100 kg/hr, the auxiliary fuel used in the incinerator is natural gas, and the when ignited the secondary burner is modulated.

Design requirements can be summarized as (a) Temperature to be maintained in the Secondary Chamber is 1100°C (b) the flue gas residence time for this temperature is about 1 second and (c) the oxygen content in flue gas should be a minimum of 6% [11].

Assumptions in the Design.

The major assumptions involved in the design process are as follows

- The design of Incinerator involves number of assumptions, the chemical empirical formula, the molecular weight and higher heating values of the components have been taken from specific tables given in design books of Incinerator. This has been summarized and shown in Table 2.
- The Input Temperature of the Waste, Fuel and Air is assumed as 15.5°C depending on our site-specific conditions [2].
- Air in general contains approximately 23 % oxygen and 77 % Nitrogen by weight.
- Air contains 0.0132 Kg H₂O/Kg dry air at 60% relative humidity and 26.7°C dry bulb temperatures.
- For any ideal gas 1Kg/mole is equal to 22.4 m³ at 0 °C and 101.3 KPa.
- Latent heat of vaporization of water at 15.5°C is 2460.3 Kj/Kg.

Calculation of Material Input

The different range of values for different types of biomedical waste characteristics have been summarized in Table 2. Robust judgment is required to make use of the table for assigning weight percentage for performing heat and material balance calculations [8].

The A1 (red bag waste) primarily consists of human tissue as observed from Table 2. Assuming that total input component of A1 is 30% of 100 kg/h (i.e., 30 kg/h), the red bag was calculated to have the following constituents as shown in Table 3.

In a similar fashion, the yellow bag primarily consists of higher fraction of polyethelene and cellulose, followed by PVC as observed from Table 2. The total input constituents of yellow bag is 70% of 100 kg/h (i.e., 70 kg/h), and the different constituents were summarized as shown in Table 4.



Table 2: Characterization of biomedical wastes [10]

1	2	3	4	5	6	7	8
Waste class	Component description	Typical component weight percentage	HHVdry basis(kj/kg)	Bulkdensityas fired(kg/m ³)	Moisture content of component	Weightedheat valuerangeof wastecomponent(k/kg)	Typical component heatvalueof wasteasfired(kj /kg)
A1 (Red bag)	Human anatomical	95-100	18600-27900	800-1200	70-90	1770-8370	2800
	Plastics swabs,	0-5	32500-46400	32500-46400	0-1	0-2300	400
	Absorbents Alcohol,	0-5	18600-27900	18600-27900	0-32	0-1400	200
	Disinfectant	0-0.2	25500-32500	25500-32500	0-0.2	0-70	50
							3450
A2	Animal anatomical	80-100	20900-37100	500-1300	60-90	1670-14840	3500
(Orange bag)	Plastic	0-15	32500-46400	80-2300	0-1	0-6960	1000
	Glass	0-5	0	2800-3600	0	0	0
	Beddings, Shavings	0-10	18600-20900	320-730	0-1880	0-1880	1400
							5900
A3(a)	Paper, swabs, cellulose	60-90	18600-27900	80-1000	0-30	7810-25110	15000
(yellow bag)	Plastic, PVC	15-30	22500-46400	80-2300	0-1	3340-13920	7540
	Sharps,	4-8	140	7200-8000	0-1	-10	10
	Needles, Alcohol,	0-0.2	16200-32500	800-1000	0-50	0-70	30
	Disinfectan	2-5	0-23200	1000-1020	80-100	0-230	70



	ts Fluids, residual						22650
A3(b)	Plastic	50-60	32500-46400	80-2300	0-1	16090-27840	21000
(yellow bag)	Sharps	0-5	140	7200-8000	0-1	0-10	0
Lab waste	Cellulosic material	5-10	18600-27900	80-1000	0-15	790-27900	1500
	Fluids, residuals	1-20	0-23200	1000-1020	95-100	0-230	70
	Alcohol,	0-0.2	25500-32500	800-1000	0-50	0-70	50
	Disinfectants Glass	15-25	0	2800-3600	0	0	0
							22620
A3(c)	Swabs, Pads	5-30	18600-27900	80-1000	0-30	630-8370	2300
(yellow bag)	Plastics	50-60	32500-46400	80-2300	0-1	16090-27840	21000
	Sharps, Glass	0-10	140	7200-8000	0-1	0-10	0
	Fluids	0-10	0-23200	1000-1020	80-100	0-460	230
							23530
B1 (bluebag)	Non-infected animal	90-100	20900-37100	500-1300	60-90	1880-14840	3000
	Anatomical	0-10	3250-4640	80-2300	0-1	0-4640	2300
	Plastic Glass	0-3	0	2800-3600	0	0	0
	Beddings, Shavings	0-10	018600-20900	320-730	10-50	00-1880	1400
							6700

Table 3: Waste generation from Red bags considering four major hospitals in Shimla and Chandigarh city used for incinerator design

Compound	Chemical Composition	Fraction assumed	Generation (kg/hr)
Tissue (dry)	C ₅ H ₁₀ O ₃	0.25	0.25 * 30 = 7.5
Water	H ₂ O	0.10	0.10 * 30 = 3.0
Ash	-	0.05	0.05 * 30 = 1.5
Swabs	C ₆ H ₁₀ O ₅	0.25	0.25 * 30 = 7.5
Plastics	(C ₂ H ₄) _x	0.35	0.35 * 30 = 10.5
Total Red bag		1.00	30

Table 4: Waste generation from yellow bags considering four major hospitals in Shimla and Chandigarh city used for incinerator design

Compound	Chemical Composition	Fraction assumed	Generation (kg/hr)
Tissue (organs)	C ₅ H ₁₀ O ₃	0.15	0.15 * 70 = 10.5
Polyethelene	(C ₂ H ₄) _x	0.30	0.30 * 70 = 21.0
PVC	(C ₂ H ₃ Cl) _x	0.20	0.20 * 70 = 14.0
Cellulose	C ₆ H ₁₀ O ₅	0.35	0.35 * 70 = 24.5
Total Yellow bag		1.00	70

Table 5: Summary of total heat generation from waste input (considering both yellow and red bag)

Compound	Chemical Composition	Calorific Value (Kj/Kg)	Total Input (kg/hr)	Total Heat in Kj/h
Tissue	C ₅ H ₁₀ O ₃	20,471	7.5+10.5 = 18	3,68,478
Cellulose, Swabs	C ₆ H ₁₀ O ₅	18,568	7.5+24.5 = 32	5,94,176
Plastic (Polyethylene - 96%)	(C ₂ H ₄) _x	46,304	10.5+21 = 31.5	14,58,576
PVC 4%	(C ₂ H ₃ Cl) _x	22,630	0+14 = 14	3,16,820
Ash	0	0	0+1.5 = 1.5	0
Moisture	H ₂ O	0	0+3.0 = 3.0	0
Total heat generation			100	27,38,050

Calculation of Heat Input of waste.

The heat generated from the waste (input value) considering both the red and yellow bags is the product of the calorific value of the specific waste type by the total amount of waste generated. The total heat generation from the waste input has been summarized and presented in Table 5. The methodology is used similar to as described in reported literature [8].

Determination of stoichiometric O₂ for wastes.

The overall stoichiometric requirement of oxygen has been determined from chemical reactions for each of the individual components of the biomedical waste and has been represented in each of the following reactions shown below

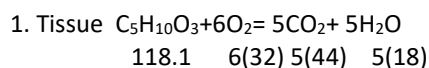



1.0 1.63 1.86 0.76
Tissue **1829.34** 33.4813.68
(as fired)

2. Polyethylene $(C_2H_4)_x + 3O_2 = 2CO_2 + 2H_2O$
28 3(32) 2(44) 2(18)
1.0 3.43 3.14 1.29
Poly **31.5** **108** 99 40.6
Ethylene (as fired)

3. PVC $2(C_2H_3Cl)_x + 5O_2 = 4CO_2 + 2H_2O + 2HCl$
2(62.5) 5(32) 4(44) 2(18) 2(36.5)
PVC 1.0 1.28 1.41 0.29 0.58
(as fired) **14** **17.92** 19.71 4.03 8.18

4. Cellulose $C_6H_{10}O_5 + 6O_2 = 6CO_2 + 5H_2O$
162 6(32) 6(44) 5(18)
1.0 1.19 1.63 0.56
Cellulose **32** **38.08** 52.16 17.92
(as fired)

To summarize,

Total combustible components of biomedical waste generated per hour = $18+31.5+14+32 = 95.5\text{kg/h}$

Total amount of oxygen required for stoichiometrically burning the biomedical waste generated per hour = $29.34+108+17.92+38.08 = 193.34\text{kg/h}$

Hence total Stoichiometric O_2 required = 193.34 kg/h for burning combustible components of the biomedical waste 95.5kg/h.

Determination of Air for Waste Based on 150% Excess

It is observed from Step 4 that the Stoichiometric O_2 requirement to burn the flammable parts of the HCW generated is 193.34 kg/h

By our assumption (Step 1) air consists of 23% O_2 , hence total amount of air required is = $193.34*(100/23) = 840.60\text{ kg/h}$

Since Air determination is based on 150% excess, the total Air requirement (150% excess) = $(1.5*840.60) + 840.60 = 2101.5\text{ kg/h}$

Material Balance

This step basically involves the mass balance of the different products of the biomedical waste and has been shown below:

Total Mass Input
Waste Input Rate = **100.0 kg/h**
Dry air (Step 5) = **2101.5 kg/h**
Moisture in air = 0.0132 (Step 1) \times **2101.5** = **27.73 kg/h**
Hence Total Mass Input = **2229.23 kg/h**
Total Mass Output (assuming complete combustion of waste)

(A) Dry Products from Waste

Air requirement for Waste = 2101.5 kg/h
Subtracting Stoichiometric air requirement (Step 5) = 840.60 kg/h

Hence, Total excess air = $2101.5 - 840.60 = 1260.9$ kg/h

Now, the stoichiometric air also consists of 77% nitrogen (Step 1) , hence Add nitrogen from stoichiometric air (77%) = $0.77 * 840.60 = 647.26$ kg/h

Total production = $1260.9 + 647.26 = 1908.16$ kg/h

Further, combustion of these products will also lead to generation of CO₂ (Step 4)

CO₂ formed from C₅H₁₀O₃ = 33.48 kg/h

CO₂ formed from (C₂H₄) x = 99 kg/h

CO₂ formed from (C₂H₃Cl) x = 19.71 kg/h

CO₂ formed from C₆H₁₀O₅ = 52.16 kg/h

Hence total CO₂ generated = $33.48 + 99 + 19.71 + 52.16 = 204.35$ kg/h

Total Waste Dry products = $1908.16 + 204.35 = 2112.51$ kg/h

(B) Moisture

Total moisture generated from Waste (Table 4) = 3 kg/h

Moisture in combustion air (Step 6) = 27.73kg/hr

Moisture generated from Combustion reactions (Step 5) = $13.68 + 40.6 + 8.18 + 17.92 = 80.38$ kg/h

Hence, total moisture generation = $3 + 27.73 + 80.38 = 111.11$ kg/h

(C) Ash

Total Ash output (Table 3) = **1.5 kg/h**

(D) HCl generation from Waste

HCl formed from (C₂H₃Cl)_x (Step 4) = **8.18 kg/h**

Total Mass Output = Sum (A, B, C, D)

Total Mass Output = **2233.30 kg/h**

Heat Balance

(A) Total Heat input generated from the Waste (Step 3, Table 4) = $Q_i = 27, 38,050$ kJ/h

(B) The Total Heat output is based on Equilibrium temperature of 1100°C and consists of different components as shown below:

1. *Radiation Loss* = This is generally assumed to be 5% of total heat available
= $0.05 * 27,38,050 = 1, 36,902.5$ kJ/h

2. *Heat to Ash* = The heat to ash is computed using the formula

$$Q = mC_p dT$$

Where, m = mass of ash (1.5 kg/h); C_p = mean heat capacity of ash = 0.831 kJ/kg°C (assumed average value);

dT = Temperature difference = (1100-15. 5) °C = 1084. 5°C

Substituting these values, $Q = (1.5) * (0.831) * (1084.5) = 1351.83$ kJ/h

3. *Heat to dry combustion Products* = The heat to dry combustion products is computed using the expression

$$Q = mC_p dT$$

Where, m = weight of combustion products (2112.51 kg/h); C_p = mean heat capacity of dry products = 1.086 kJ/kg°C (assumed average value); dT = Temperature difference = (1100-15. 5)°C = 1084. 5°C

Substituting these values, $Q = (2112.51) * (1.086) * (1084.5) = 24, 88,044.57$ kJ/h

4. *Heat to moisture* = The heat to moisture is computed using the expression

$$Q = mC_p dT + mH_v$$

Where, m = weight of water (111.11 kg/h); C_p = mean heat capacity of water = 2.347 kJ/kg°C; dT =

Temperature difference = (1100-15. 5)°C = 1084. 5°C; H_v = latent heat of vaporizations of water = 2460.3 kJ/kg

Substituting these values, $Q = (111.11 * 2.347 * 1084. 5) + (111.11 * 2460.3)$

$$Q = 2, 82,810.67 + 2, 73,363.93 = 5, 56,174.60 \text{ kJ/h}$$

The Total Heat output = $Q_o = \text{Sum (1, 2, 3, 4)} = 31,82,473.5 \text{ kJ/h}$

Net Heat Balance = $Q_i - Q_o = 27, 38,050 - 31, 82,473.5 = - 444,423.5 \text{ kJ/h}$ (Heat insufficiency)

Hence, Auxiliary fuel must be supplied to achieve Design temperature of 1100°C.

Auxiliary Fuel Requirement to Achieve 1100°C

(a) Total heat required from auxiliary fuel = Heat deficiency (Step 7) + 5% radiation loss from the required heat

Hence, Total heat required from auxiliary fuel = $444,423.5 \text{ (Step 7)} + 0.05 \cdot (444,423.5)$ Or, Total heat required from auxiliary fuel = **4, 66,644.68 kJ/h**

(b) The Available net heat from natural gas at 1100°C and 20% excess air (assumption) = **15,805.2 kJ/m³**.

$$\begin{aligned} \text{The flow rate required for Natural gas to maintain the temperature of } 1100^\circ\text{C} \\ = 4, 66,644.68 / 15,805.2 \text{ m}^3/\text{h} = \mathbf{29.52 \text{ m}^3/\text{h}} \end{aligned}$$

Products of Combustion from Auxiliary Fuel

(i) Dry Products from Fuel at 20% Excess Air = $16.0 \text{ kg} \cdot 29.52 \text{ m}^3/\text{h} \text{ m}^3 \text{ fuel} = \mathbf{472.32 \text{ kg/h}}$

(ii) Moisture From Fuel = $(1.59 \text{ kg} / \text{m}^3) \cdot 29.52 \text{ m}^3/\text{h} = \mathbf{46.94 \text{ kg/h}}$

Secondary Chamber Volume Required to Achieve One Second Residence Time at 1100 °C

(i) Total Dry Products (waste and fuel) = $2112.51 \text{ kg/h (Step 6a)} + 472.32 \text{ kg/h (Step 9(i))} = \mathbf{2584.83 \text{ kg/h}}$

Assuming, dry products have the properties of air and using the ideal gas law, the volumetric flow rate of dry products (dp) at 1100°C (Vp) can be calculated as follows:

$$V_p = 2584.83 \text{ kg dp/h} \cdot (22.4 \text{ m}^3/29 \text{ kg dp}) \cdot (1373\text{K} / 273\text{k}) \cdot (1 \text{ h}/3600\text{s}) = \mathbf{2.79 \text{ m}^3/\text{s}}$$

(ii) Total Moisture (waste and fuel) = $111.11 \text{ kg/h (Step 6b)} + 46.94 \text{ kg/h (Step 9(ii))} = \mathbf{158.05 \text{ kg/h}}$

Using the ideal gas law, the volumetric flow rate of Moisture at 1100°C (Vm) can be calculated as follows:

$$V_m = (158.05 \text{ kg H}_2\text{O/h}) \cdot (22.4 \text{ m}^3/18\text{kg H}_2\text{O}) \cdot (1373\text{K}/273\text{k}) \cdot (1 \text{ h}/3600\text{s}) = \mathbf{0.28 \text{ m}^3/\text{s}}$$

$$\text{Total Volumetric Flow Rate} = \text{Sum } (V_p, V_m) = 2.79 + 0.28 = \mathbf{3.07 \text{ m}^3/\text{s}}$$

Hence it is observed from the design that a volume of 3.07 m³ with one second retention time is sufficient for the active chamber. In reality, the chamber will have some dead spaces wherein there will be no or negligible flows and these are not accounted for in the design calculation of retention volume. Further, while dimensioning the secondary chamber, the length of chamber should be calculated from the flame front to the location of the temperature sensing device to maintain the retention time of one second [8].

Residual Oxygen in the Flue Gas

The residual oxygen in the flue gas can be determined using the following expression

$$\text{Excess Air} = \% \text{ Residual O}_2 / (23\% - \% \text{ Residual O}_2)$$

In our assumption, we have assumed that excess air is 150% and air contains 23% of Oxygen

Substituting these values in above equation, the residual oxygen in flue gas was determined to be 13.8%

RESULTS AND DISCUSSIONS

The above section describes the design of an incinerator for a waste of 500kg/day generated from four major hospitals in a 100 km radius of towns Shimla and Chandigarh. Though many reported literature exists regarding assumptions and design considerations for design of incinerator, such detailed design

calculations (particularly detailed mass balance approach and heat requirements) are often not easily available and hence comparisons of such designs are often difficult.

However, in Indian context, a similar such design was reported for Chikmagalur city for eleven hospitals and 27 private clinics with a daily waste generation of about 85kg/day and design waste of 100kg/day [8]. It was observed from the mass balance analysis that for complete combustion a greater mass was generated for our study locations (2229.23kg/hr) in comparison to Chikmagalur city for which the rate of generation was found to be 1607.6 kg/hr [8]. This is primarily because the design waste was significantly higher for our study conditions (500kg/day) than reported for Chikmagalur city (100kg/day). Further, it was observed from both the studies that additional heat requirements were provided using auxiliary fuel, as the design waste was insufficient to generate the required heat to maintain the design temperature. The additional heat requirement for the present study was observed to be slightly higher (444423.5 kJ/hr) in comparison to Chikmagalur (412802. kJ/hr) [8]. It was further observed that volume of the primary and secondary chamber for the incinerator for our study conditions was 8m³ and 3.07m³ respectively while for Chikmagalur they were reported to be 5m³ and 2.17m³ respectively [8].

CONCLUSIONS

The following main conclusions were drawn from the design of the incinerator system

1. The amount of waste generated is about 500kg/day considering the four most important hospitals located in Shimla and Chandigarh within a vicinity of 100km (Distance between Shimla and Chandigarh is 100km).
2. A Multiple Chamber Incinerator has been designed with an operating capacity of 100kg/hr.
3. The dimensions of the Primary Chamber of the incinerator were 2.16 x 1.23 x 3 m.
4. The material balance analysis assuming complete combustion shows that the total mass input (2229.23 kg/hr.) is almost equal to the total mass output (2233.30 kg/hr.)
5. The heat balance analysis showed that the total amount of heat generated from the input waste was 27,38,050 kJ/hr, whereas the total heat requirement was 31,82,473.5 kJ/hr for complete combustion. Hence, the deficient heat requirement of 444423.5 kJ/hr was required to be supplied by auxiliary fuel to maintain a temperature of 1100°C.
6. From the design analysis it was determined that the flow rate of the natural gas was required to be maintained at 29.52 m³/hr to neutralize the heat deficit and maintain the temperature at 1100°C.
7. The design volume of secondary chamber is found to be 3.07 m³ to maintain a retention time of 1 second.

REFERENCES

- [1] Aarne Vesilind, P., Jeffrey Peirce, J. and Ruth Weiner, 1994. *Environmental Engineering*, 2nd Edition, Butterworth Heinemann.
- [2] Bio-medical Waste Management, June 2004. Environmental Management and Policy Research Institute (EMPRI)
- [3] Prachi Vasistha, 2016. 'Study of Biomedical Waste Generation and Management for Public and private Sector Hospitals', M.Tech project report submitted at Jaypee University of Information Technology
- [4] Chandorkar, A.G. and Nagoba, B.S. 2004. *Hospital Waste Management*. Paras Medical Publishers, 2nd Edition.
- [5] Coker, A.O. et al. 1999. *Characterization and Management of solid Hospital Waste*, 25th WEDC Conference, Addis Ababa, Ethiopia, Page No. 331-334.
- [6] Central Pollution Control Board 2000. *Manual on Hospital Waste Management*, March, 2000.
- [7] Estimation of Bio-medical Waste Generation Rates, 2003. State of Environment Report (SOER), KSPCB, Page No. 146-148
- [8] John, S.E., Swamy, C.N. 2011. Design of Incinerator for the treatment of biomedical solid wastes in Chikmagalur city. *Journal of Industrial Pollution Control*, 27(2), 173-179
- [9] *Handbook of Operation and Maintenance of Hospital Medical Waste Incinerators*, 1990. USEPA, EPA..No. 625-6-89-024.
- [10] Incinerator design and operating criteria volume II Biomedical waste incinerators' Ontario Ministry Of The Environment 135 St. Clair Avenue West Toronto, Ontario October 1986.



- [11] Trivedy, R.K. 2010. *Handbook of Environmental Laws, Rules, Acts, Guidelines, Compliances and Standards*. B.S. Publications, Hyderabad, India.
- [12] Xie R., Jidong L., Jie L., Jiaqiang Y., "A burning Experiment Study of an Integral Medical Waste Incinerator." *Energy and Power Engineering*, vol. 2, pp. 175-181, July 2010.