

Research Journal of Pharmaceutical, Biological and Chemical Sciences

ECG Signal Denoising Using EEMD and Adaptive Filter.

V Amala Rani*, Bhimavarapu Tirumalareddy, and CH Ajay Babu.

Department of Electronics and Instrumentation, Sathyabama University, Tamil Nadu, India.

ABSTRACT

Electrocardiogram (ECG) signal recording which is used for the detection of various heart diseases is corrupted by power line interference. This method is being proposed for removal of power line frequency from ECG signals using in Ensemble Empirical Mode Decomposition (EEMD) and adaptive filter. EEMD is a relatively new, data sending to adaptive filter and using adaptive technique to decompose ECG signal into a series of Intrinsic Mode Functions (IMFs). The adaptive filter is designed to remove the power line interference and the reference signal of which is generated by selectively reconstruction of IMFs. To evaluate the performance of the adaptive filter, reference ECG signals are used. The result obtained by this new method indicates that the power line interference of ECG signal is removed effectively.

Keywords: Adaptive filter, powerline interference, Ensemble Empirical Mode Decomposition

**Corresponding author*

INTRODUCTION

Power line interference often severely corrupts electrocardiogram (ECG) signal. ECG has been used extensively for detection of heart disease, which records the electrical activity of the heart generated by the heart muscle. The ECG signal is weak biopotential signal, the ratio of signal noise of which is low [1]. When the ECG signal is recorded, the cable linking the patients to the monitoring equipment is susceptible to 50Hz/60Hz power line interference, the frequency of which is very close to the high frequency component of the ECG signal and therefore is more difficult to filter out.

Removal of the power line interference in ECG signal has been an important research area [2]. In last decades many methods of removal of base line interference were proposed. They can be categorized into non-adaptive and adaptive filtering. Nonadaptive filter actually is a sharp notch filter which is a band-stop filter with a narrow stop-band [3]. It passes all frequencies except the frequencies centered on a centre frequency: 50/60Hz in a stop band. The method is easy to implement at low cost. However it causes undesirable signal distortion due to the overlapping of signal and disturbance. The interferences are eliminated but the useful important frequency components of ECG signal are also removed. Its performance also depends on the frequency stability of the power line. The adaptive filtering was first proposed by Widrow. The method doesn't disturb the ECG frequency spectrum but it requires reference signal. The coefficients of the filter can be updated adaptively by tracking the statistical characteristics of the reference signal [6]. The selections of the reference signal are important which control the performance of the adaptive filter.

In this paper, a completely unique methodology is proposed to get rid of the power line interference in cardiogram signal supported Ensemble Empirical Mode Decomposition (EEMD) and adaptive filter. ECG signal can be adaptively rotten into Intrinsic Mode Functions (IMFs) by EEMD. The facility line interference will be roughly modelled by a curving signal that is truly one amongst the IMFs. Then the approximate power cable interference will be acquired by the selective reconstruction of IMFs which might be regarded as the logical thinking signal of adaptive filter. Then the adaptive filter will be designed to effectively take away time varied power cable frequency in cardiogram signal.

MATERIALS AND METHODS

Ensemble Empirical Mode Decomposition (EEMD)

Empirical mode decomposition (EMD), a data analysis technique, is used to denoise non-stationary and non-linear processes. The method does not require any pre & post processing of signal and use of any specified basis functions [4]. But EMD suffers from a problem called mode mixing. So to overcome this problem a new method known as Ensemble Empirical mode decomposition (EEMD) has been introduced.

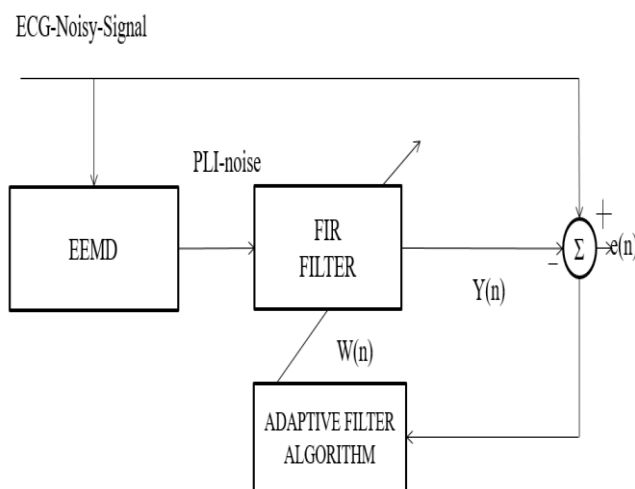

Figure 1: Block Diagram using EEMD

Empirical Mode Decomposition (EMD)

Empirical Mode Decomposition was being introduced by Huang for analysing the non-linear and non-stationary signal [14]. EMD efficiently overcome the limitations of above described methods [5]. It is an iterative process which decomposes real signals x into elementary signals (modes). In this method, first the signal is decomposed in to a number of IMF [4]. For this the condition of IMF has to be verified which are given below:

- a. The number of extrema as well as the number of zero crossings has to be either equal or differ at most by one for the whole data set.
- b. At any data point, the mean value of the envelope defined by means of the local maxima and the envelope defined by means of the local minima are zero.

Procedure

- a. Compute a mean envelope $m_1(t)$ of the signal $x(t)$.
- b. Let $h_1(t) = x(t) - m_1(t)$ be the residue.
- c. If $h_1(t)$ is an IMF, STOP; or else, treat $h_1(t)$ (with its extrema) as a new signal to obtain $h_{1.1}(t)$.
- d. If $h_{1.1}(t)$ is an IMF, STOP; or else, continue the same process

$$\begin{aligned}
 & h_{1.1}(t) = h_1(t) - m_{1.1}(t) \\
 & \dots\dots \\
 & h_k(t) = h_{1,k-1}(t) - m_{1,k}(t)
 \end{aligned}$$

Generally, after a finite number k_1 times, $h_{1,k_1}(t)$ will be an IMF, denoted by $IMF_1(t)$, the first IMF. Set $r_1(t) = x(t) - IMF_1(t)$. And repeat the shifting procedure:

$$\begin{aligned}
 & r_2(t) = r_1(t) - IMF_2(t) \\
 & \dots\dots \\
 & r_n(t) = r_{n-1}(t) - IMF_n(t)
 \end{aligned}$$

The process ends when r_n has at most one extrema and n is the total number of decomposed IMF. Thus $x(t)$ is decomposed into finitely many IMFs.

$$x(t) = \sum_{i=0}^n IMF_i(t) - r_n(t)$$

EEMD Process

When a signal has intermittency the EMD algorithm described above may encounter the problem of mode mixing [7]. The frequent appearance of mode mixing is a single Intrinsic Mode Function (IMF) either consisting of signals of widely disparate scales, otherwise a signal of a similar scale residing in different IMF components [4]. The intermittence causes serious aliasing in the time-frequency distribution as well as makes the individual IMF devoid of physical meaning. To overcome this limitation a new noise assisted data analysis (NADA) method is being proposed, the ensemble empirical mode decomposition (EEMD) [15]. This novel approach is based on the recent studies of the statistical properties of Fractional Gaussian noise that showed the EMD is efficiently an adaptive dyadic filter bank when applied to fractional Gaussian noise.

Algorithm

The steps for EEMD are as follows.

- a) Initialize the number of ensemble l .

- b) Generate $x^i(t) = x(t) + w^i(t)$ ($i=1, 2 \dots I$) are different realization of white Gaussian noise.
- c) Each $x^i(t)$ ($i=1 \dots I$), is fully decomposed by EMD getting their modes $IMF_k^i[t]$, where $k=1, 2 \dots K$ indicates the modes.
- d) Assign \overline{IMF}_k as the k -th mode of $x[t]$, obtained as the average of the corresponding IMF_k^i : $\overline{IMF}_k[t] = \frac{1}{I} \sum_{i=1}^I IMF_k^i[t]$.

Just as the EMD method, the given signal $x(t)$ could be reconstructed according to the following equation:

$$x(n) = \sum_{k=1}^K \overline{IMF}_k(t) + \bar{r}(t)$$

Where $\overline{IMF}_k[t] = \frac{1}{I} \sum_{i=1}^I IMF_k^i[t]$ and $\bar{r}(t) = \frac{1}{I} \sum_{i=1}^I r_i[t]$

The EEMD described here employ all the important characteristics of noise. Its principle is when a group of white noise is added to the objective signal it cancels each other out in a time space as one mean. The reason is clear that the added white noise could populate the whole time-frequency space uniformly with the constituting components of different scales separated by the filter bank.

Adaptive filter design

An adaptive filter is that the natural alternative for removal of power line interference which may adjust its coefficients according to a particular rule [13]. Least mean sq. (LMS) algorithm developed by Window and Hoff is that the most generally used adaptive filtering rule that is easy and powerful [3].

A gradient descent is used to estimate a time varying signal. The coefficients are adjusted to minimize the mean square error between its output and an unknown system. The filter consists of two main functional blocks: the reconstructed reference signal based on EEMD and the adaptive unit based on LMS algorithm [4]. The original ECG signal corrupted by power line interference is decomposed into a series of IMFs that are extracted from the local high frequency to local low frequency. EEMD can act as a dyadic filter bank with adaptive bandwidth which could separate the signal components in the temporal domain. If the original signal $x(t)$ decomposed by EEMD can be expressed as follows: $x(t) = \sum_{i=1}^N c_i(t)$, the frequency of IMF $c_1(t), c_2(t), \dots, c_N(t)$ is decreasing.

So the low-pass filter can be built as: $x_L(t) = \sum_{i=L}^N c_i(t) \quad 1 \leq L \leq N$,

The high-pass filter can be expressed as: $x_H(t) = \sum_{i=1}^H c_i(t) \quad 1 \leq H \leq L$.

EEMD filter is nonlinear and intermittent and it works in time domain. The power line interference is approximately satisfied with the conditions of IMF. It can be selectively reconstructed by IMFs and regarded as the inference signal of the adaptive filter.

Once the reference signal is determined, the LMS algorithm of the adaptive filter can be generalized as follows:

1. Initializes the W and the order of the filter is 1.

$$y(n) = d(n)w(n)$$

2. Outputs:

$$e(n) = x(n) - y(n)$$

3. Coefficient update:

$$W(n - 1) = w(n) + 2\mu e(n)d(n)$$

The step-size μ directly affects how quickly the adaptive filter will converge.

RESULTS AND DISCUSSION

The ECG signal is corrupted by power line interferences and sampled at 360 Hz. The power line interference could be clearly observed from the spectrum of the signal shown in figure.

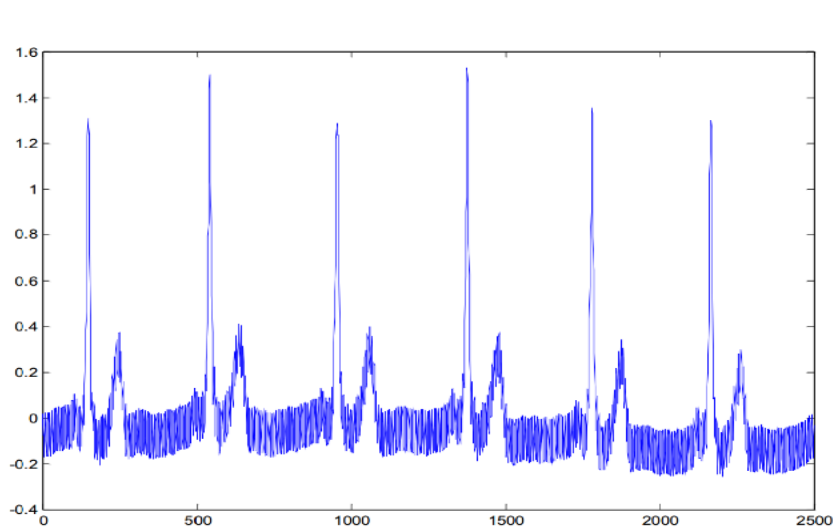

Figure 2: ECG Signal Corrupted by Power Line Interference

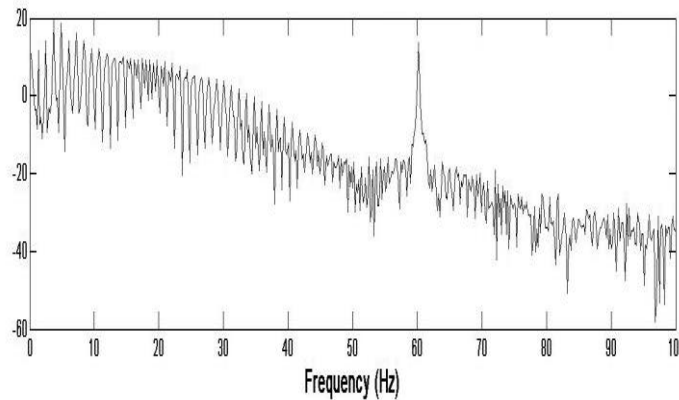

Figure 3: Spectrum of the signal

The ECG signal is decomposed into seven IMFs and one residue, which are shown in left panels and the spectrum by FFT are given in right panels. From the spectrum of IMFs it can be seen that EEMD can act as a dyadic filter bank. EEMD can decompose signal adaptively into IMFs that have more physically meaningful interpretation according its local time scale characteristics.

The highest frequency oscillations are first picked out, and then next IMF contains lower frequency oscillations than the one extracted. The 50Hz power line interferences can be presented in special IMFs. The first IMF seems to be a good representation of the power line interferences that have relatively regular time scale and approximate the standard IMF. The spectrum of the first IMF not only contains 50Hz component but also other high frequency component which maybe have useful information.

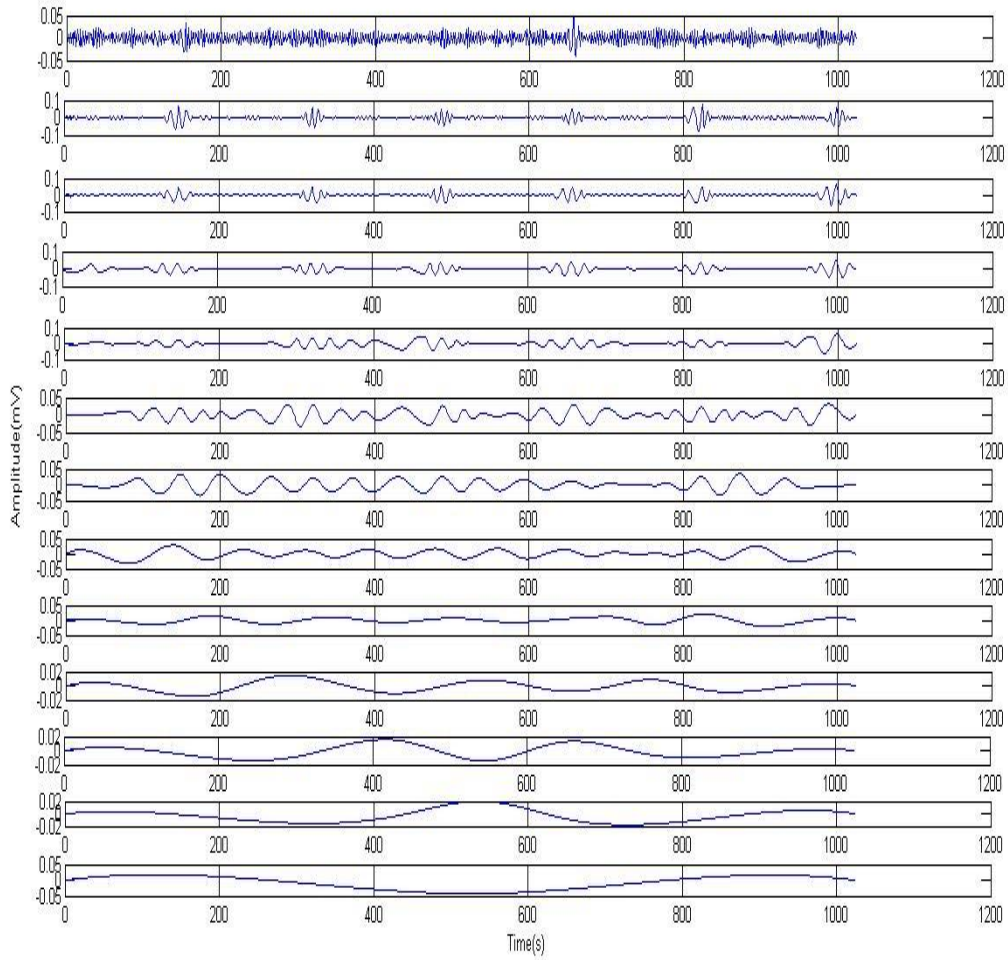

Figure 4: IMF of the signal

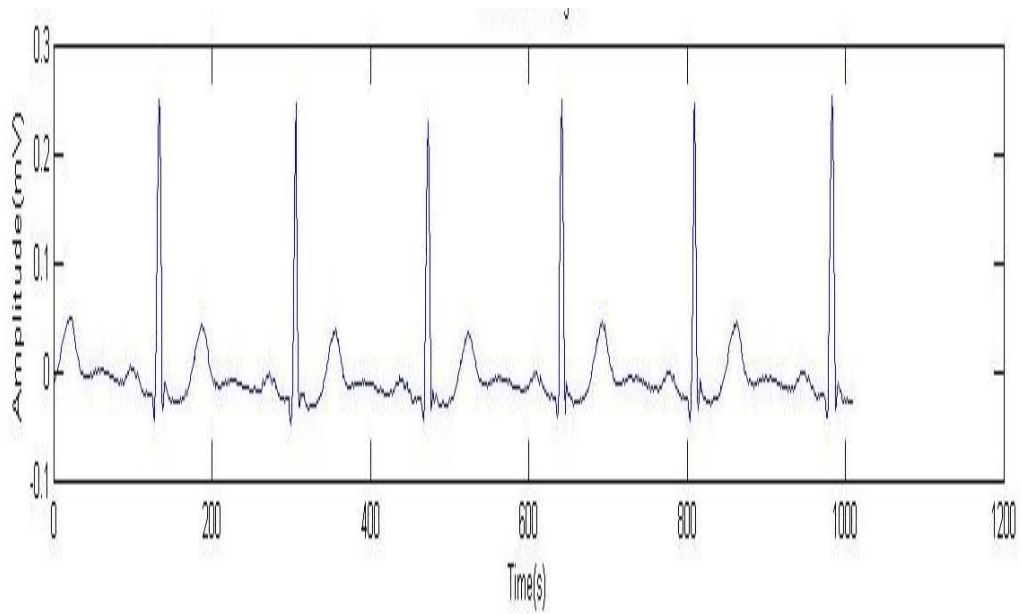

Figure 5: ECG signal output of Adaptive filter

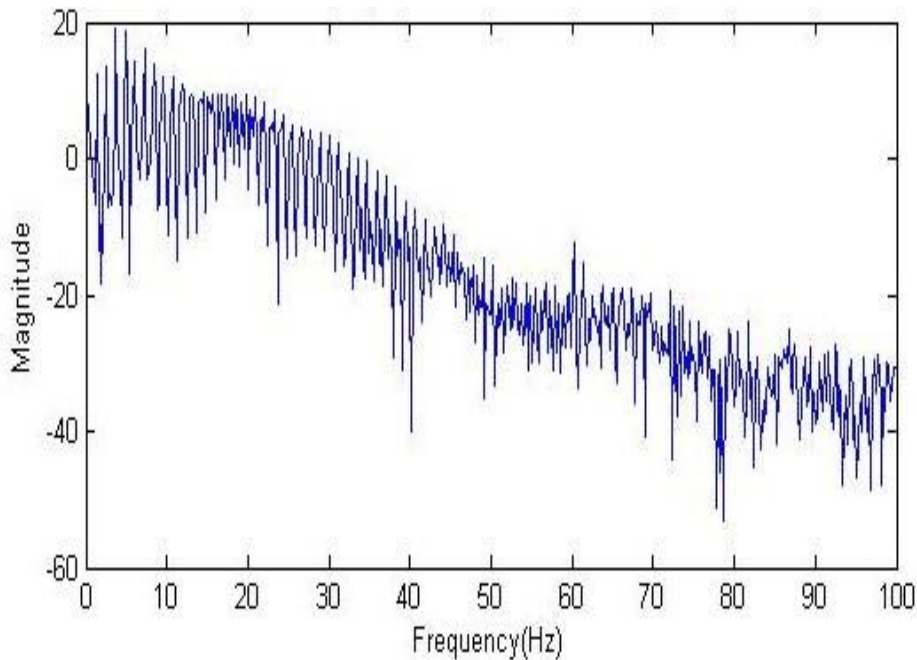

Figure 6: Spectrum of final ECG signal

If only the first IMF is filtered out, the reconstructed ECG will produce distortion of waveform. The first IMF can be selected as the reference signal of the adaptive filter. The output of the adaptive filter is shown in fig. From visual inspection, the power line interference is effectively removed without distortion of the ECG signal. The characteristic of the ECG signal can also be clearly identified.

CONCLUSIONS

The power line interference might severely corrupt associate cardiogram recording. Removing the facility line interference in cardiogram signal is typically the required pre-processing step to reinforce the signal characteristics for designation. In this, a new method is projected for removing power line interference in ECG signals supported EEMD and adaptive filter. After that performance of the tactic is tested with actual cardiogram signals. Results indicate that the tactic is powerful and helpful and therefore the power-line interference would be eliminated from the cardiogram signal without touching its spectrum.

REFERENCES

- [1] Aung Soe Khaing, Zaw Min Naing International Journal of Information and Electronics Engineering, 2011; 1: 210-216
- [2] Imteyaz Ahmad, F Ansari, U.K. Dey International Journal on Computer Science and Engineering, 2015; 7: 13-18.
- [3] Snehal Thalkar, Dhananjay Upasani International Journal of Scientific & Engineering Research, 2013; 4: 12-23.
- [4] Megha Agarwal, R.C.Jain Journal of Electronics and Communication Engineering, 2013; 5: 60-65.
- [5] Manuel Blanco-Velasco, Binwei Weng, Kenneth.E.Barner Computers in Biology and Medicine, 2008; 38: 1-13.
- [6] Md.Ashfanor Kabir, Celia Shahnaz Biomedical; Signal Processing and Control, 2012; 7: 481-489.
- [7] Kang-Ming Chang Sensors (Basel), 2010; 10: 6063-6080.
- [8] J. Leski and N. Henzel Signal Processing, 2004; 35: 781-793.
- [9] George Tsoilis and Thomas D. Xenos International Journal of Signal Processing, Image Processing and Pattern Recognition 2011; 4: 91-106.
- [10] Jesmin Khan , Sharif Bhuiyan , Gregory Murphy , Mohammad Alam Journal of Biomedical Image Processing, 2014; 1: 45-56.
- [11]] R. Swarnalatha, D. V Prasad Journal of Applied Sciences, 2010; 10: 319-324.
- [12] Sayadi. O, Shamsollahi. M. B IEEE Trans. Biomed Eng., 2008; 55: 2240-2248.



- [13] Thakor. N. V, Zhu. Y. S IEEE Trans. Biomed. Eng., 1991; 38: 785–794.
- [14] Rovin Tiwari, Prof. Rahul Dubey, Prof. N.K. Mittal Journal of Electronics and Communication Engineering, 2014; 9: 61-66.
- [15] Chengwei Li, Liwei Zhan and Liqun Shen Entropy 2015; 17: 5965-5979.