

Research Journal of Pharmaceutical, Biological and Chemical Sciences

The Physiological Requirements for the Engineering of Milking Machines to Reduce Mastitis.

Ivan Vasil'evich Kapustin*, Vitaly Anatol'evich Grinchenko, Dmitry Ivanovich Gritsay, and Elena Ivanovna Kapustina.

*Stavropol State Agrarian University, Zootekhnicheskiiy lane 12, Stavropol 355017, Russia.

ABSTRACT

The relevance of the research problem is mismatch and mode of operation of existing milking machines physiological characteristics of milking cows. The aim of the article is the description of improved construction the milking machine with elektrical-pulsatorbased on linear motor, which will reduce traumatizes animals and their mastitis. It will provide an increase in milk production and improve the efficiency dairy farming as a whole. The article will be useful to scientists involved in the physiology of milking and engineering milking equipment.

Keywords: prevention of mastitis, physiology milking, efficiency of dairy cattle, milking machine, elektrical-pulsator, rubber nipple.

**Corresponding author*

INTRODUCTION

World practice in dairy cattle confirms the dominance machine milking in large livestock farms and complexes, which uses high-milking machines and robots, so and small like private farms. The leading manufacturers on the market milking equipment now are company «Westfalia» (Germany), «De Laval» (Sweden) and S / A / Cristensen & Co (Denmark).

Dairy farms in Russia currently apply suction milking domestic production, working in push-pull (DA-2M-1M ADU, ADU-1-03, ADU-1-04) and three-stroke mode (YES-ZM, «Volga» HELL 1/3) with a synchronous gear teat cups. Milking machines are also used foreign companies «Westfalia», «DeLaval», SA Christensen & Co (SAC).

In spite of all the variety construction of milking machines, all of the models with greater or lesser degree of inherent disadvantages, which determined by operating parameters the device to matched for physiological animal requirements. This expressed the high mechanical effect on a nipple and udder, which provokes inflammation and mastitis. Practice shows, in some cases, because this reason every third cow continually discarded [9, 12].

RESULTS AND DISCUSSION

One of the main shortcomings of the existing milking machines is a hard mode due to sudden transients from sucking to the cycle of the compression, causing reverse current milk, keratinization nipples, cracking and congestive phenomena in the tissues of the udder during milking. The result is the transfer of bacteria from one quarter of an udder quarter of a cow in the other, the increase in the mastitis bacteria on the teat skin, causing inflammation of the udder, which increases the risk of new infection. Also, it does not fully implemented Section cows and used their genetic, which ultimately leads to the milk producers lost profits and reduced profitability of the industry as a whole [2, 8, 10].

Confirmation that the teat cup liner in compression contributes to the emergence of reverse current of milk in the teat canal, are the results of our studies performed to determine the nature of its deformation in the teat cup (the transition from sucking to the cycle of the compression stroke). Driving experimental teat cup and the diagram of liners, compression forces are show in Figure 1.

Analysis of the resulting chart shows that the compressive force nipple in the zone of sphincter has a maximum value and decreases to the base, which is the root cause of the reverse current milk [5, 7].

This problem is great social significance, because milk, which obtained from cows with mastitis, contains pathogenic bacteria (toxins), is a potent poison, resistant to heat treatment.

The sanitary requirements and regulations of the milking machine demanded the milk from the part udder infected mastitis should be disposed of, and the rest, after boiling can be use for animal feed. If manual milking mastitis does not exceed 3...5%, in machine milking, this figure may reach 50%, which leads to a complete loss of production [1, 3, 4].

The greatest damage for dairy farming is subclinical mastitis. According to the International Dairy Federation of Clinical mastitis suffer about 2% of the cows, and subclinical – 50%.

In the Stavropol State Agrarian University was developing the milking machine, in which the drive of the teat cups is provided a radically new design electrical-pulsator a linear motor. The innovative idea of the development is to use electrical-pulsator to create vacuum fluctuations, which correspond to the physiological characteristics of the process of milk in cows due to the replacement of the solenoid on a linear motor.

The control panel sets mode of operation the milking machine. When the control panel is turned off, the magnetizing coil electrical-pulsator 11 and 12 are de-energized, and the armature 7 in the lower position. Thus, the poppet valve 16 is positioned at the bottom and under the action of vacuum across the opening 3 in the wall 2, covering the supply of vacuum in the chamber 5. Conical valve 15 connected via a rod 6 with the armature of the linear motor 7 it is also in its lowest position. The air fills the atmospheric pressure chamber 5

AC vacuum through the pipe 19 extends into the chamber between the walls of the teat cups. Liners contracts, which prevents air flow through the teat cups.

After control panel turned on, the teat cups put on the nipples. Depending on the mode of milking at the magnetizing coils 11 and 12 are supplied control signals. The linear motor allows to manage the dynamics of motion of the armature 7, consequently, the valve cone 15. When the armature 7 takes the uppermost position, the valve cone 15 closes the atmospheric passage 20 and the hole 3 in the wall 2 is open because the poppet valve 16 rises focus 17. Vacuum through conduit 18 fills the chamber 4 and a constant vacuum through an orifice 3 of the vacuum chamber 5 of the variable, and then extends through the conduit 19 into the chamber between the walls of the teat cups. There is a flow of air between the walls of the chambers of the teat cups and the teat rubber takes its original position. Milk under the influence of the pressure difference inside the udder and teats under the jet take out in added chamber teat cup and one on the milk hose assigned to the milking pail. There is a cycle of sucking.

The control panel gives the duration of cycle of sucking and compression. Unlike existing models elektrical-pulsator, engineering model allows to control the duration of transients in the interspace chambers of the teat cups (Figure 3). Thus, elektrical-pulsator a linear motor allows to form the working cycle of the milking machine and compression strokes of sucking, as well as transients. The number of cycles is specified number of pulses and the duration of the cycles determines the ratio of cycles. The control unit allows you to set the adaptive milking mode variable frequency fluctuations, the duration and the ratio of clock cycles. Equipment elektrical-pulsator two or four linear motors enables milking paired anterior and posterior parts of the udder, or to milking each part separately with a certain regime.

Elektrical-pulsator control system is set up so that during a transitional phase and in the first magnetizing coil linear motor current is zero, and the second - increases to a maximum, the valve elektrical-pulsator abruptly descends, overlapping the atmospheric valve. Interwall chamber teat cup filled with a vacuum, the teat rubber straightens. For phase and constructive-regime parameters are as follows:

$$t_a = 0,1 \text{ c}; I_1 = 0; I_2 \uparrow; X \rightarrow \min.$$

B phase characterized by the maximum current in the magnetizing coil and a second de-energized first, as a result, the valve closed, and the chamber between the walls of the teat cup to fill the vacuum, the teat cup liner fully straightened. There is a clock milking. Options for phase b:

$$t_b = 0,4 \text{ c}; I_1 = 0; I_2 = 800 \text{ mA}; X = 0.$$

During the transition phase from an anchor slid upward, the valve gradually opens, feeding air into the chamber inter wall teat cups. The current in the first magnetizing coil increases to a maximum, and the second reduced to a minimum. Liners gradually shrinks. The parameters for the phase are as follows:

$$t_c = 0,3 \text{ c}; I_1 \uparrow; I_2 \downarrow; X \rightarrow \max.$$

D phase characterized by the maximum current in the first coil and the second de-energized. Anchor linear motor held in the upper position, resulting elektrical-pulsator valve opened, and the chamber between the walls of the teat cups filled with atmospheric air, the teat cup liner is compressed. There is a rhythm recreation. Options for phase d:

$$t_d = 0,2 \text{ c}; I_1 = 800 \text{ mA}; I_2 = 0; X = \max.$$

The process repeated cyclically in the same manner.

The main parameters elektrical-pulsator are parameters (shape and size) of the valve cone and the effort to anchor the linear motor.

To design the conical valve provided the minimum resistance to air flow during transients from sucking to the beat of the compression stroke, the drag coefficient ϵk should be minimal. This will adjust the duration of the transient by moving the cone valve. Analyzing the plane dependency of the drag coefficient ϵk

cone valve from moving X_1 with different diameters D_A atmospheric channel (Figure 4), and taking into account the condition $0,1 \leq \frac{X_1}{D_A} \leq 0,5$, ϵk minimum value achieved when moving X_1 is: $X_1 = \frac{D_A}{2}$.

When moving the valve varies the gap through which the leakage of atmospheric air into the interwall chamber teat cup. S_g gap area is the area of the right side surface of a truncated cone (Figure 5). Thus, the area S_g gap determined by the formula:

$$S_g = \frac{\pi}{2} (D_A + D_Y) \sqrt{\frac{(D_A - D_Y)^2}{4} + X_Y^2}$$

где: D_Y – diameter of the lower base of the gap, m;
 X_Y – gap height, m.

The control panel gives duration bars sucking and compression. Unlike existing models pulsates developed design allows you to control the duration of transients in the interspace chambers of the teat cups. Thus, electrical-pulsator a linear motor allows to form the working cycle of the milking machine and compression strokes of sucking, as well as transients. The number of cycles is specified number of pulses and the duration of the cycles determines the ratio of cycles. The control unit allows you to set the adaptive milking mode variable frequency fluctuations, the duration and the ratio of clock cycles. Equipment electrical-pulsator two or four linear motors enables milking paired anterior and posterior lobes of the udder, or to milking each part separately with a certain regime.

CONCLUSION

Figure 6 shows the waveforms of the work pulsates valve-membrane type (dashed line) and electrical-pulsator (solid line). Electrical-pulsator provides an increase in the duration of the phase «C» of 20-25%, which eliminates the sharp contraction of liners, providing a so-called «gentle» milking mode by reducing the mechanical stress on the teat tissue and reverse current exclusion of milk. Production tests electrical-pulsator affirmed its performance and its advantageous characteristics.

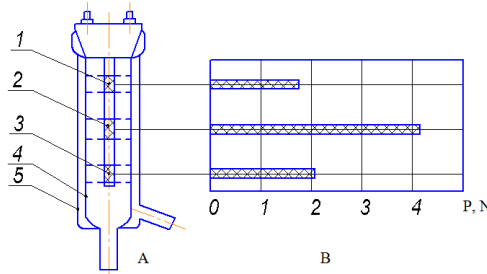

1, 2, 3 – pressure sensors; 4 – rubber nipple; 5 – the carcass of the teat cup
 Figure 1: Experimental teat cup (A) and chart compression forces rubber nipple (B)

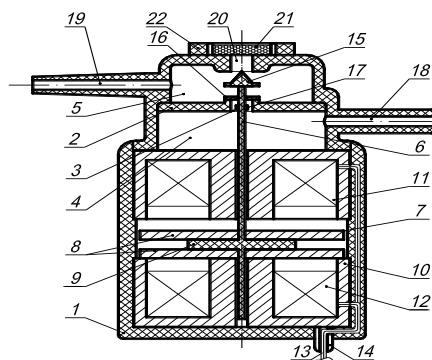

1 - the case; 2 - partition; 3 - aperture; 4 - constant vacuum chamber; 5 - AC vacuum chamber; 6 - stock; 7 - anchor; 8 - magnetically drives; 9 - non-magnetic layer; 10 - yokes; 11, 12 - magnetizing coils; 13 - conclusions coils; 14 - cable entry; 15 - cone valve; 16 - poppet; 17 - emphasis; 18 - constant vacuum tube; 19 - AC vacuum tube; 20 - the atmospheric channel; 21 - Filter; 22 – cover

Figure 2: Elektrical-pulsator milking machine based on linear motor

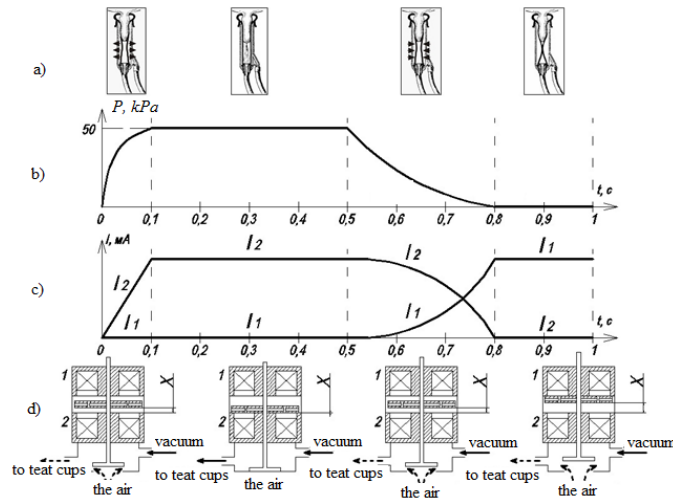

Figure 3: Interaction between the constructive-regime parameters elektrical-pulsator fluctuations in phases

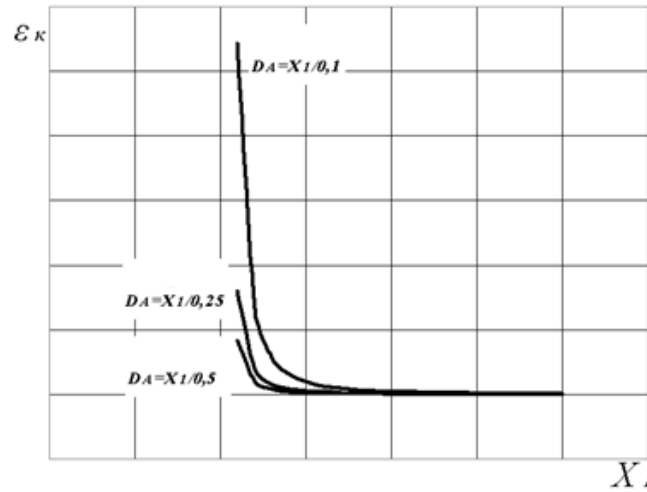

Figure 4: Graphs of coefficient for resistant ek cone valve moving at different ratios X_1 and outside diameter D_A channel

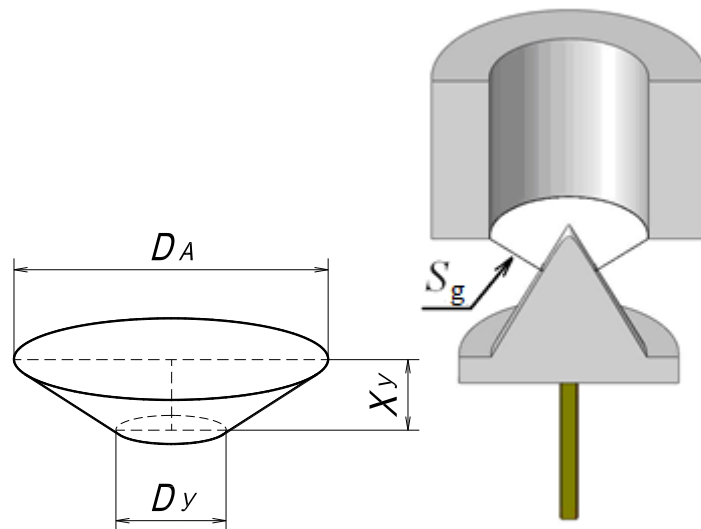

Figure 5: View of the gap through which the leakage of air

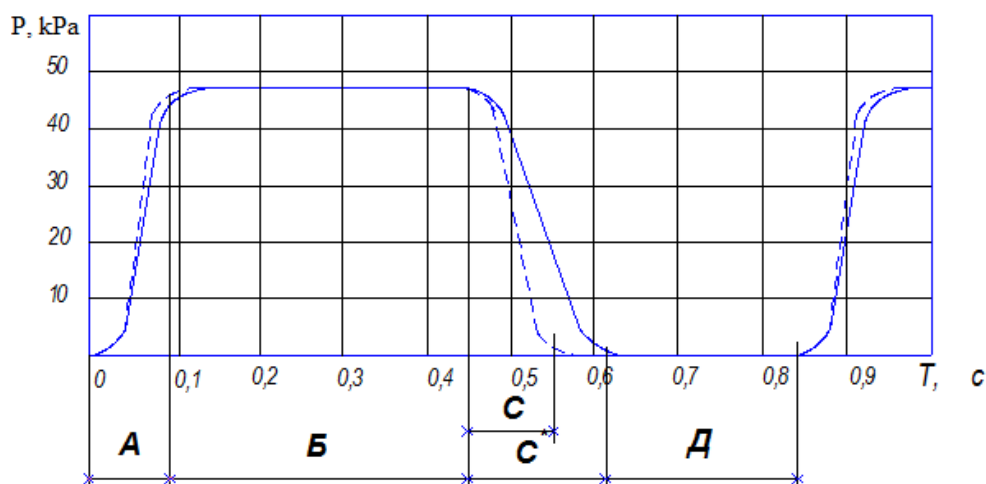

Figure 6: Waveforms work Milking machines pulsate

REFERENCES

- [1] Juricek, J. Overovanie funkcie elektromagnetickyh pulzatorov // Polnohospodarstvo. – 1991. – T. 37. – p. 263-268.
- [2] Manus sentral pulsering for mjolkestall // ProvemeldingNorgeslandbrukshogskole. Inst. for tekn. fag. – Norge, 1992. – Vol. 673. – 5 p.
- [3] Patent RF № 95222, MPK8 A 01 J 5/14. Elektropulsatoroiloilnogoapparata / Nikitenko G. V., Kapustin I. V., Grinchenko V. A.; zaiavitelipatentoobladataelStavrop. gos. agrar. un-t. - № 2010108042/22; zaiavl. 04.03.10; opubl. 27.06.10.
- [4] Anton Alekseyevich Nesterenko, Nadezhda Viktorovna Kenijz and Sergei Nikolayevich Shlykov. Res J Pharm Biol Chem Sci 2016;7(1):1214 -1220.
- [5] Anatoli Georgievich Molchanov, Valeriy Georgievich Zhdanov, Aleksandr Valentinovich Ivashina, Alexey Valerevich Efanov, Sergei Nikolayevich Shlykov and Ruslan Saferbegovich Omarov. Res J Pharm Biol Chem Sci 2015;6(6):633-637.
- [6] Vladimir Vsevolodovich Sadovoy, Viktor Ivanovich Guzenko, Sergei Nikolayevich Shlykov, Ruslan Saferbegovich Omarov and Tatiana Viktorovna Shchedrina. Res J Pharm Biol Chem Sci 2015;6(6):613-616.
- [7] Natalja Jurevna Sarbatova, Vladimir Jurevich Frolov, Olga Vladimirovna Sycheva, and Ruslan Saferbegovich Omarov. Res J Pharm Biol Chem Sci 2015;6(4):962-965.
- [8] Ivan Vyacheslavovich Atanov, Vladimir Yakovlevich Khorol'skiy, Elena Anatolievna Logacheva, Sergey Nikolaevich Antonov and Ruslan Saferbegovich Omarov. Res J Pharm Biol Chem Sci 2015;6(6):671-676.
- [9] Vladimir Ivanovich Trukhachev, Galina Petrovna Starodubtseva, Olga Vladimirovna Sycheva, Svetlana Ivanovna Lubaya, and Marina Vladimirovna Veselova. Res J Pharm Biol Chem Sci 2015;6(4):990-995.
- [11] Shaliko Zhorayevich Gabriyelyan, Igor Nikolaevich Vorotnikov, Maxim Alekseevich Mastepanenko, Ruslan Saferbegovich Omarov, and Sergei Nikolayevich Shlykov. Res J Pharm Biol Chem Sci 2015;6(3):1345-1350.
- [12] Vladimir Ivanovich Trukhachev, Vladimir Vsevolodovich Sadovoy, Sergei Nikolayevich Shlykov, and Ruslan Saferbegovich Omarov. Res J Pharm Biol Chem Sci 2015;6(2):1347-1352.